

Available in other formats including  
braille, large print and audio CD. Please  
go to [ee.co.uk/help](https://ee.co.uk/help) or call **0330 1234 150**

## TV BOX MINI

User guide

## WELCOME TO EE TV

Over the next few pages you'll find everything you need to get your EE TV Box Mini up and running.

### Contents

Getting started	2
Your remote	5
Parental control and payment PINS	6
Using EE TV	7
EE TV App	7
What your TV Box lights mean	8
Accessibility tools	9
Need some help?	10

# GETTING STARTED

Important: before you set up your TV Box, make sure your broadband is up and running.

1

## Plug in

Plug in your HDMI® cable to the purple socket (see page 4).

Depending on your TV, you might need to use a specific HDMI port for Ultra HD and HDR.

To get the best possible picture quality, make sure you use the HDMI cable we sent you.

Visit [ee.co.uk/help](http://ee.co.uk/help) for more information.

2

## Choose how you want to connect

You can connect your TV Box to your Smart Hub using either WiFi or ethernet.

### A: Connecting by WiFi?

The range of the TV Box can vary significantly depending on location, obstructions and interference.

Place your TV Box no more than one wall, ceiling or floor away from your Hub or Smart WiFi device and limit the amount of electrical equipment and other WiFi devices close to your TV Box.

For optimum WiFi performance the TV Box should be set up within 5 metres line of sight of your hub or Smart WiFi.

Go to step 3.

### B: Connecting by Ethernet cable?

Connect your hub to your TV Box (yellow socket) using the ethernet cable we sent you (see page 4).

3

## Power up

Plug your TV Box into the nearest socket on the wall.

**Important:** use the power supply unit provided in your TV Box pack.

Press the power button on the front of your TV Box to turn it on.

4

## Set up your remote

Activate the batteries by removing the protector strip and press the power button. The remote control will automatically pair with the TV Box and programme itself to control your TV as well.

5

## Follow the on screen instructions

Simply follow the on screen instructions which will guide you through the set up process and introduce you to your EE TV service.

- HDMI cable** (connect to TV)
- 2A:** Connect your Hub to your TV Box via WiFi  
**2B:** Connect your Hub to your TV Box via ethernet cable
- Power supply cable** (use power cable provided in box)

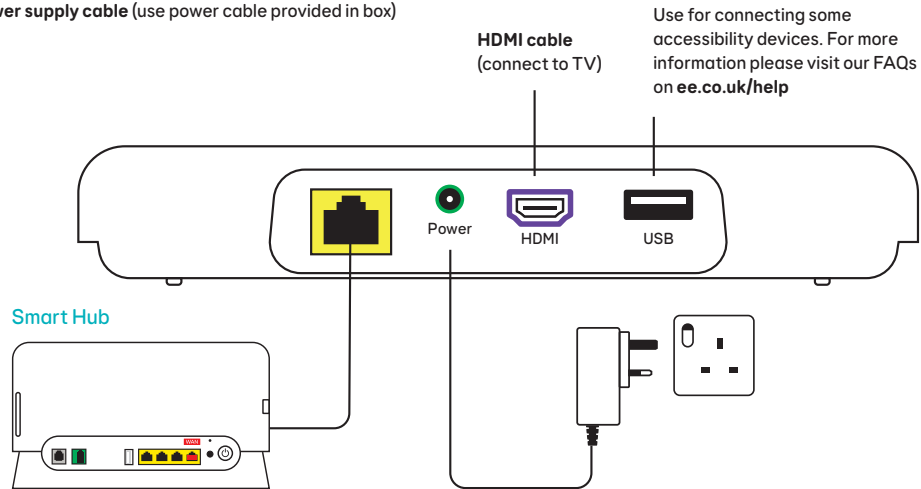

## YOUR REMOTE

Your remote uses Bluetooth to control your TV Box. It can only be paired to one TV Box at a time. You can also use it to control most TV's, so there's no need to use separate remotes.

### On/off

To switch off your TV, press and hold.

### Source

Use to select your TV box and switch between devices connected to your TV.

### Home

Brings up the main menu, apps and recordings.

### Volume

Controls your TV volume when paired.

### Coloured buttons

Look out on-screen for the coloured buttons as these allow quick navigation to certain features and screens.



### More

Access to accessibility features like audio description, subtitles and zoom.

### Guide

See what's on TV and radio for the next 7 days.

### Search

Search for content across all TV and on demand players.

### Record

No current function.

### Numeric keypad

Can be used to type in letters and to jump through recordings, for example, 1 = 10%, 9 = 90%.

## PARENTAL CONTROL AND PAYMENT PINS

Take control over what your kids stumble across (and rent) by setting up parental control.

### Parental control PIN

To control access to programmes with an age rating.

The default PIN is 1234.

You can change it at any time in  (Settings).

If you forget your parental control PIN, go to [ee.co.uk/help](https://ee.co.uk/help)

### Payment PIN

To buy films or TV shows on the EE Player. You can have the same PIN for both if you like.

If you forget your payment PIN, call us on **0330 1234 150** or go to [ee.co.uk/help](https://ee.co.uk/help) to find out how to reset your TV box.

**Note:** You may need to set up other PINs or passwords to access other players like Amazon or Netflix.

## EE TV APP

Once downloaded, you can log in to the app with your EE or BT ID to watch live and catch up content. You can also watch films and TV shows you've purchased, offline.



## WHAT YOUR TV BOX LIGHTS MEAN

When you press the buttons on the remote control, the status light blinks aqua to confirm the command has been received.

Front of your TV box

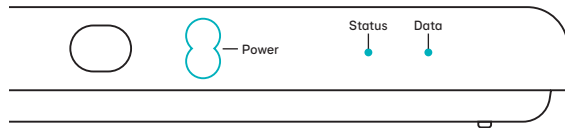

	Power	Status	Data
Box on	Aqua	Off	Off
Box in standby	Off	Off	Off

## ACCESSIBILITY TOOLS

Click the ☰ icon and you'll find a range of accessibility features to help you watch your EE TV service:

- Audio Description
- Subtitles
- Sign language

Not all broadcasters allow these features, but if they do you can turn them on/off in ⚙️ (Settings).

The screen's appearance and text can be changed, too. Click on **Appearance** and you can switch on High Contrast, remove channel logos and remove transparency, which will make the menus and text easier to read.

You can also use the Zoom feature to make text bigger in the Guide (live channels) or in Apps (On demand channels), which can be found in ☰ (More), and switched on or off by selecting (OK).

Or you can use a UK USB keyboard, either alongside the remote or instead of it. Just plug your keyboard into the back of your TV box and use the keys like you would on a remote control.

You can find out more about these at [ee.co.uk/help](https://ee.co.uk/help)

Grid 3 Software is available for Windows PCs and tablets, which allows you to control your TV box with touch, switch, eye gaze and pointing devices. Find out more at [thinksmartbox.com](https://thinksmartbox.com)

## NEED SOME HELP?

- If you need any help, [ee.co.uk/help](https://ee.co.uk/help) is a good place to go. We've got common questions and answers that will help you solve any problems you may be having, and other tips with getting the most out of your service.
- If you'd like to get in contact with us then you can find all of our details at [ee.co.uk/contact-ee](https://ee.co.uk/contact-ee)
- You can speak to us on the phone too. Anytime between 08:00 and 21:00 Monday to Friday and 08:00 and 20:00 Saturday and Sunday. Call us for free on 150 from a BT landline, or from an EE or BT mobile in the UK. If you're calling from any other UK provider, use 0330 1234 150 (charged at national rates). International call costs vary.

## SAFETY AND LEGAL INFORMATION

### Important safety and care instructions

Keep for future reference



Your TV box Mini (model DIW3930) from EE is manufactured to comply with European safety standards. Please read the following instructions carefully before installing and using it.

### Installation and location

- For indoor use only in the UK
- Position all parts, including power adapters away from heat and sun (e.g. away from radiators, window sill or other electrical equipment which can get hot)
- Keep area ventilated (e.g. don't put in cupboards or back of sofas) and don't block any vents with objects or thick carpets
- Keep device flat on its feet at all times. Not standing it as designed could cause overheating
- Keep device and cables out of young children's reach
- Only use power adapters provided by EE for this specific device. See [ee.co.uk/help](https://ee.co.uk/help) for further information or contact our helpdesk if you need a replacement
- Electronic devices hate liquids; don't place devices and power adapters in damp areas or near sources of water or splashes
- This device uses wireless technology; check before using or installing where restrictions may apply such as in hospitals
- The Ethernet port is intended to be connected to devices in the same building and on the same earth circuit
- When connecting a USB peripheral device, respect the way of insertion and don't use force
- Product may cause scratches or marks if placed on fragile surfaces (e.g. veneered wood or delicate fabrics); place on a mat if required
- Don't use near flammable substances or in a flammable atmosphere (e.g. warehouse or garage)
- Designed for use at room temperatures between 0 and 40°C

### Care and maintenance

- Treat all parts with care; no shock or vibration, and don't pull or twist any cables
- Regularly check your product for damage to ensure small parts aren't exposed
- Unplug from the mains socket before cleaning
- Dust with a soft dry cloth; no water or solvent
- Regularly check that objects don't cover any parts or any vents which could cause overheating
- When not in use, store in a dry place and away from extreme heat or cold

### Warnings

- If any parts of your product, power adapters or any cables appear damaged, discontinue use immediately. Switch off your electrical socket if it is safe to do so and contact our helpdesk
- Don't try to open your device or power adapters. There are no serviceable parts and you risk an electrical shock
- This device has been evaluated for and shown to be compliant with European Guidelines when installed and operated with a minimum distance of 20cm between the unit and your body
- If you've got a pacemaker please check with your doctor before installation

### Battery safety information

- Only use batteries of same size and type as originally supplied
- Take care when disposing of your product. The battery could explode if placed in a fire, a hot oven or is crushed or cut
- Don't subject the product to extremely low air pressure as the battery may explode or leak flammable liquid or gas

### Returning and Recycling Equipment

#### Disposing of your old electrical and electronic equipment

The Government has a legal requirement to minimise the unsorted waste disposal of electrical and electronic equipment and to maximise its separate collection and environmentally sound management. The symbol shown here and, on a product, means you shouldn't throw it in your normal rubbish at the end of its working life.



This product may contain substances that could be harmful to people or the environment if it's not recycled correctly.

The equipment provided to you will remain the property of EE / BT at all times (excluding outright sale equipment). You'll need to return it back to us within 60 days of telling us you want to cancel, or we may need to charge you for it. You can do this by following the steps here: [ee.co.uk/returns](https://ee.co.uk/returns)

As the environment is important to EE, we can get rid of it in an environmentally friendly way.

If this equipment is a replacement for something similar, then you can also dispose of your old kit by following the instructions above.

### Legal information

#### EU – Radio Equipment Directive

##### Declaration of Conformity

Hereby, EE Ltd declares that the radio equipment type TV Box (Model DIW3930) is in compliance with Directive 2014/53/EU. The full text of the EU declaration of conformity is available at [ee.co.uk/declaration-of-conformity](https://ee.co.uk/declaration-of-conformity)

#### UK – Radio Equipment Directive

##### Declaration of Conformity

Hereby, EE Ltd declares that the radio equipment type TV Box (Model DIW3930) is in compliance with Radio Equipment Regulations 2017. The full text of the UK declaration of conformity is available at [ee.co.uk/declaration-of-conformity](https://ee.co.uk/declaration-of-conformity)



### Restrictions:

This radio equipment is subject to certain restrictions when it is placed on the market in:

Belgium (BE), Bulgaria (BG), Czech Republic (CZ), Denmark (DK), Germany (DE), Estonia (EE), Ireland (IE), Greece (EL), Spain (ES), France (FR), Croatia (HR), Italy (IT), Cyprus (CY), Latvia (LV), Lithuania (LT), Luxembourg (LU), Hungary (HU), Malta (MT), Netherlands (NL), Austria (AT), Poland (PL), Portugal (PT), Romania (RO), Slovenia (SI), Slovakia (SK), Finland (FI), Sweden (SE), Northern Ireland (UK(NI)), Norway (NO), Switzerland (CH), Iceland (IS), Turkey (TR), Lichtenstein (LI).

Wi-Fi 5 GHz: The frequency band 5150-5350 MHz is limited to indoor use.

This radio equipment is also subject to certain restrictions when it is placed on the market in United Kingdom (UK).

In accordance with the relevant statutory requirements in the UK, the 5150 to 5350 MHz frequency range is restricted to indoor use in the United Kingdom. This device can only be used in the UK as it may use frequencies in the 5.725 – 5.850 GHz band which are not allowed elsewhere in Europe

### Radio transmission information TV Box

#### TV Box (Model DIW3930)

Frequency in range (GHz)	Max power in the range (dBm)
2.4 – 2.4835	20
5.15 – 5.35	23
5.47 – 5.725	30
5.725 - 5.850	23

#### Remote Control

Frequency in range (GHz)	Max power in the range (dBm)
2.4 – 2.4835 GHz	3.9

To turn off the set-top box's Wi-Fi, simply plug in the Ethernet cable provided between your set-top box and your Gateway.

### Power consumption and power supply information

Information can be found at [ee.co.uk/help](http://ee.co.uk/help)

### Opensource software

The TV Box (Model DIW3930) contains code that is covered by the GNU (General Public Licence (GPL). In accordance with the GPL, EE has made the relevant code available for download at [ee.co.uk/help](http://ee.co.uk/help)

### Trademarks

#### YouView

YouView is subject to terms of use, suitable broadband speed, TV aerial and coverage. See [www.youview.com](http://www.youview.com). Software contained in this device is licensed on a limited basis. All other rights are reserved. YouView and the YouView logo are trademarks of YouView TV Limited and are used under licence. © YouView TV Limited 2010–2022. All logos and content images are trademarks and/or copyright of their respective owners. Images are for illustration only and may differ on screen. Content is subject to availability.



#### Dolby

Manufactured under license from Dolby Laboratories. Dolby, Dolby Audio and the double-D symbol are trademarks of Dolby Laboratories Licensing Corporation.



#### HDMI

The terms HDMI, HDMI High-Definition Multimedia Interface, and the HDMI Logo are trademarks or registered trademarks of HDMI Licensing Administrator, Inc.



#### Bluetooth

Bluetooth® is a registered trademark of Bluetooth SIG, Inc.



#### HEVC ADVANCE

Covered by one or more claims of the patents listed at [patentlist.hevcadvance.com](http://patentlist.hevcadvance.com)

#### MPEG LA AVC

This product is licensed under the AVC patent portfolio license for the personal and non-commercial use of a consumer to: (i) encode video in compliance with the AVC standard ("AVC-video") and/or (ii) decode AVC video that was encoded by a consumer engaged in a personal and non-commercial activity and/or was obtained from a video provider licensed to provide AVC-video.

No license is granted or shall be implied for any other use. Additional information may be obtained from MPEG LA, LLC see [www.mpegla.com](http://www.mpegla.com)

### Microsoft PlayReady

This product contains technology subject to certain intellectual property rights of Microsoft. Use or distribution of this technology outside of this product is prohibited without the appropriate license(s) from Microsoft.

Content owners use Microsoft PlayReady™ content access technology to protect their intellectual property, including copyrighted content. This device uses PlayReady technology to access PlayReady protected content and/or WMDRM-protected content. If the device fails to properly enforce restrictions on content usage, content owners may require Microsoft to revoke the device's ability to consume PlayReady-protected content. Revocation should not affect unprotected content or content protected by other content access technologies. Content owners may require you to upgrade PlayReady to access their content. If you decline an upgrade, you will not be able to access content that requires the upgrade.

### Intertrust

Portions Copyright © 2004 – 2018, Intertrust Technologies Corporation and its licensors. All rights reserved.

### Others

All other brands and logos are trademarks or registered trademarks of their respective owners.