



# Synergy 2150

YOU MUST SUBSCRIBE TO YOUR NETWORK  
PROVIDER'S CALLER DISPLAY  
SERVICE BEFORE YOUR  
SYNERGY 2150 WILL  
DISPLAY THIS  
INFORMATION

**Digital cordless telephone and answering machine featuring DECT**

# User Guide

This equipment is not designed for making emergency telephone calls when the power fails.  
Alternative arrangements should be made for access to emergency services.

This product is intended for connection to analogue public switched telephone networks  
and private switchboards in the United Kingdom.

**Please open this page for an 'at a glance'  
guide to your Synergy 2150.**



**Please open this page for a further  
'at a glance' guide to your Synergy 2150.**



**Please open this page for a further  
'at a glance' guide to your Synergy 2150.**



# At a glance

## Del

Scrolls up through the display.

Deletes numbers on the display before dialling.

## Talk

Press to make and answer calls or to use in handsfree mode.

## Power/Secrecy

Switches the handset on and off.

During a call, mutes your voice so your caller cannot hear you, and you can talk privately to someone else in the room.

Locks the keypad so you cannot press the buttons accidentally.

## LNR

Press to redial the last number called.

Inserts a Pause when storing a number in the memory.

## Options

Opens the set up menu.

Confirms setting you want.

## Int

Lets you make an internal call or transfer a call.

## Phonebook

Scrolls down through the display.

Displays the directory.

## End

Press to end a call.  
Press to step back through options menu.

## Keypad

## Recall

Used to access some BT Select Services and when using your phone with a switchboard.

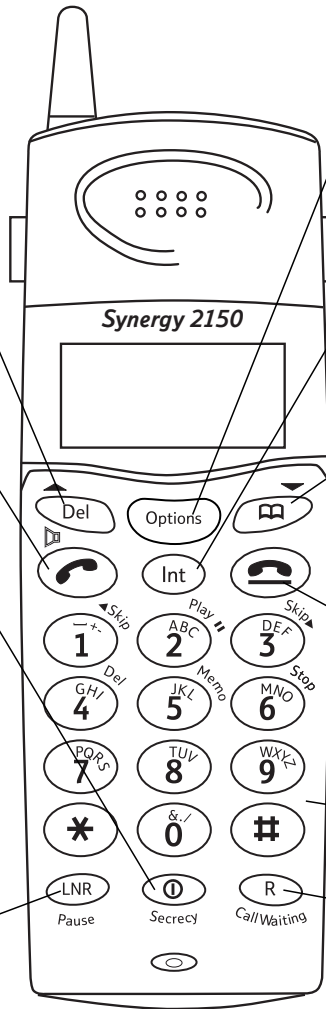

## Base

### Charging light

Comes on when the handset batteries are being charged and goes off when they are fully charged.

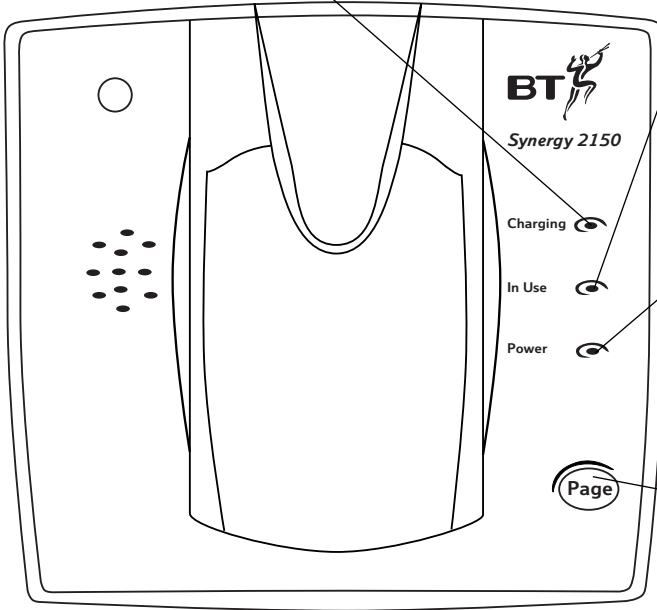

### In use light\*

Comes on when the line is in use. Flashes when a message has been left or a call has been logged.

\*Will also flash in registration mode.

### Power light

Comes on while the mains power is switched on. Flashes to indicate Day/Time needs setting.

### Page

Press to page the handset from the base.

## Display symbols

1. Indicates programming mode.
2. TAM on/off/messages (when flashing).
3. External line is in use.
4. Handset in use.
5. Indicates an internal call or when transferring a call to another handset.
6. Secrecy feature is on. Your caller cannot hear you.
7. Battery status indicator.
8. Confirms active signal between handset and base.
9. Handset loudspeaker.
10. Handset number.
11. A new call has been received.

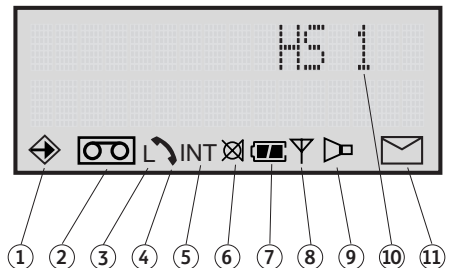

# MENU STRUCTURE

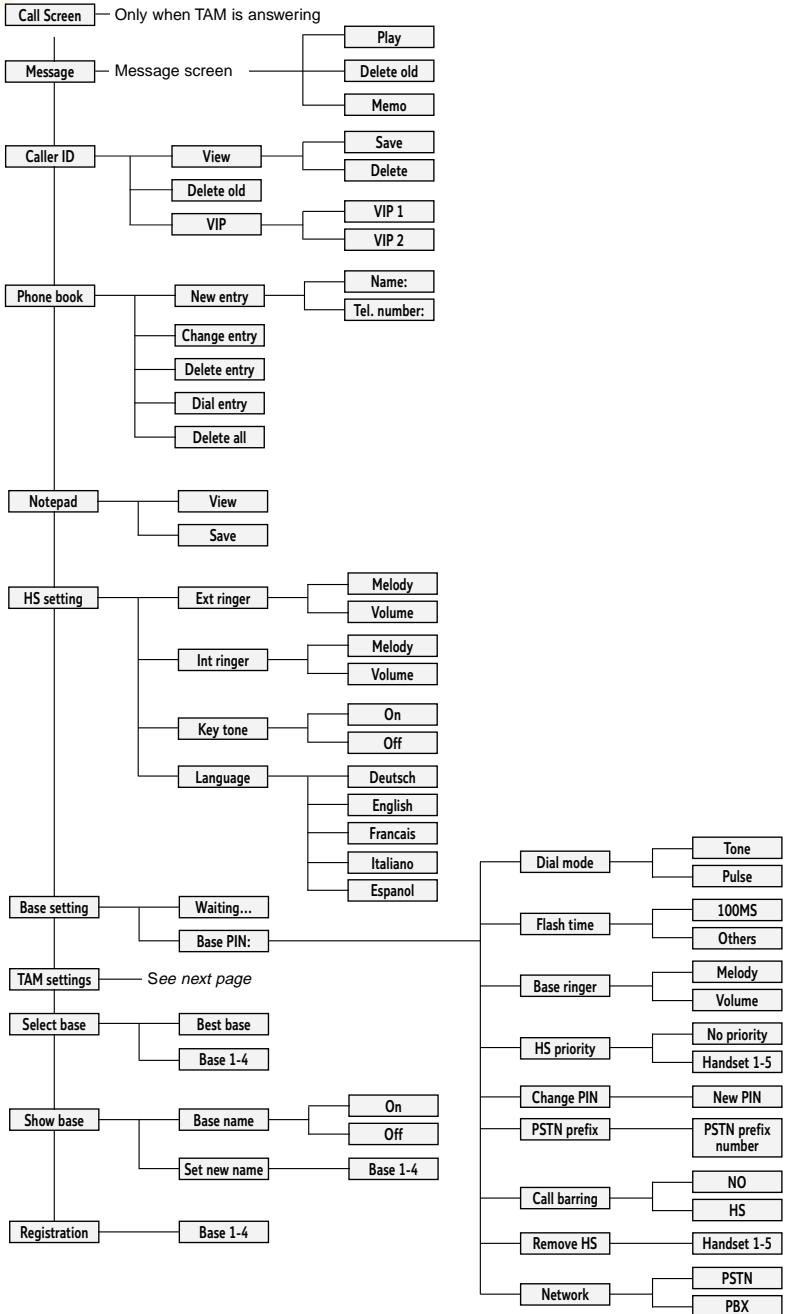
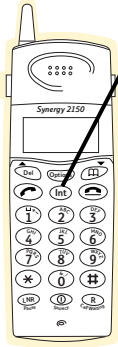

# MENU STRUCTURE FOR THE ANSWERING MACHINE

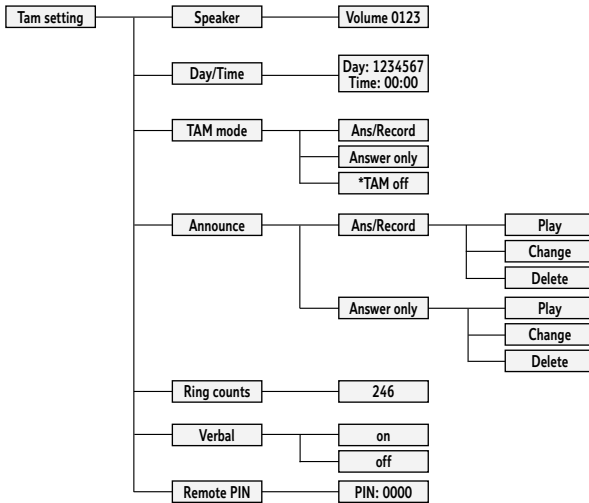

## Answering machine features

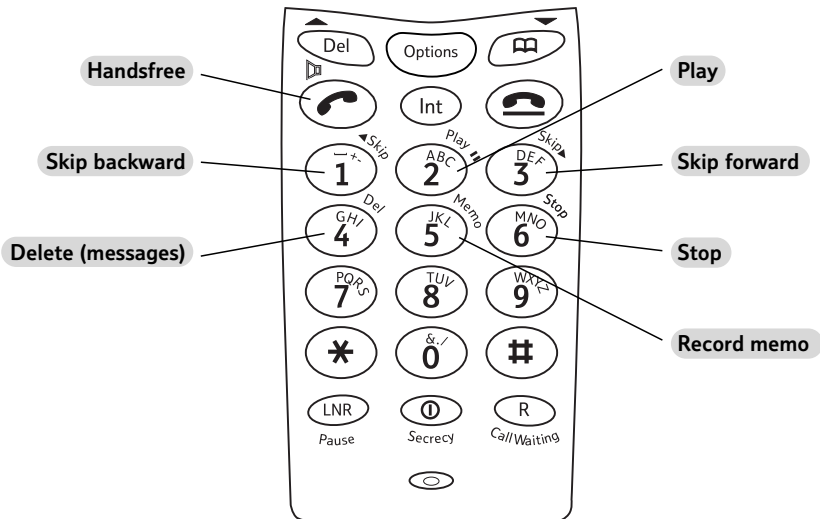



# *In this guide*

<b><i>At a glance</i></b>	<b><i>1</i></b>
<b><i>Key features</i></b>	<b><i>5</i></b>
<b><i>Introduction</i></b>	<b><i>7</i></b>
<i>Unpacking your Synergy 2150</i>	<i>8</i>
<i>For your records</i>	<i>8</i>
<b><i>Safety instructions</i></b>	<b><i>9</i></b>
<b><i>Setting up</i></b>	<b><i>10</i></b>
<b><i>Using your Synergy 2150</i></b>	<b><i>13</i></b>
<i>Making and receiving calls</i>	<i>13</i>
<i>Using the notepad</i>	<i>17</i>
<i>Using the phonebook</i>	<i>18</i>
<b><i>Using your Synergy 2150 answering machine</i></b>	<b><i>21</i></b>
<i>Message playback</i>	<i>26</i>
<i>Remote access</i>	<i>29</i>
<i>Remote access quick guide</i>	<i>30</i>
<b><i>BT Select Services</i></b>	<b><i>31</i></b>
<i>Using Caller display</i>	<i>31</i>
<i>Using VIP feature</i>	<i>33</i>
<i>Call waiting</i>	<i>33</i>
<i>Other services</i>	<i>34</i>
<b><i>Optional settings</i></b>	<b><i>35</i></b>
<b><i>Base station settings</i></b>	<b><i>37</i></b>
<b><i>Using additional handsets</i></b>	<b><i>41</i></b>
<b><i>Operating with additional base stations</i></b>	<b><i>44</i></b>
<b><i>Connecting to a switchboard</i></b>	<b><i>45</i></b>
<b><i>Maintenance</i></b>	<b><i>47</i></b>
<b><i>Help</i></b>	<b><i>48</i></b>
<b><i>Technical information</i></b>	<b><i>50</i></b>
<b><i>Technical specification</i></b>	<b><i>51</i></b>
<b><i>Index</i></b>	<b><i>52</i></b>

## **Hints and tips boxes**

*In this user guide, we've included helpful tips and useful notes. They are shown in a white box like this.*

# Key features



## Up to five handsets work from one base

You can make internal calls between handsets, transfer an external caller to another handset and hold three way calls between two handsets and an external caller.

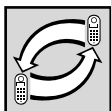

## Make internal and external calls at the same time

With the maximum of five handsets registered to the base station, your Synergy 2150 lets you use all of them together. One handset can be making an external call while the other four handsets are being used to make separate internal calls.



## Enhanced call clarity

Highly advanced digital technology (DECT) ensures much clearer calls than the older style phones.

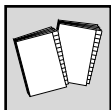

## 20 name and number directory

Store up to 20 of your most important or frequently dialled names and numbers in the phonebook. It's then easy to display and dial numbers in the phonebook. Each handset has an individual directory.



## Excellent handset range

Under ideal conditions you can use your Synergy 2150 handset at up to 300 metres from the base station outside, or up to 50 metres inside.

## Notepad

Saving you the need of a pen and paper, you can simply note down a phone number on your Synergy 2150 handset's memory during a call. You can then look the number up later or add it to the phonebook.

## minute recording capacity

Offers the benefits of digital recording.

## Caller Display & Calls Log

Let's you know who's calling you before answering the telephone, allowing you to decide whether or not to answer the call.

## Handsfree via handset

This function lets you keep your hands free, for example, to take notes. It also enables others in the same room to hear and join in the call.

### **Remote access**

You can call your Synergy 2150 from another TouchTone telephone to switch it on or play back your messages.

### **Last 5 number redial**

Display and redial any of the last five numbers called from your handset.

### **Keypad guard**

This prevents accidental dialling while carrying the handset around.

# Introduction

Your Synergy 2150 has been designed for ease of use and made to the high standards set by BT.

Please read the instructions carefully before use and retain this user guide for future reference.

## DECT

By purchasing the Synergy 2150 you now own a product which combines the advantages of cordless operation with the performance of a high quality corded telephone. It complies with the Digitally Enhanced Cordless Telecommunications (DECT) standard and offers unparalleled quality and features.

## Building up a phone system

You can use up to 5 handsets with your Synergy 2150 base station without the need for additional wiring.

This user guide applies to both single and multiple handset systems. The internal call functions described in this guide apply only to Synergy 2150 base stations with more than one handset connected.

### Important

*If you wear a hearing aid, please note that the Synergy 2150 works by sending radio signals between the base station and the handset. These signals can interfere with hearing aids, causing a humming noise.*

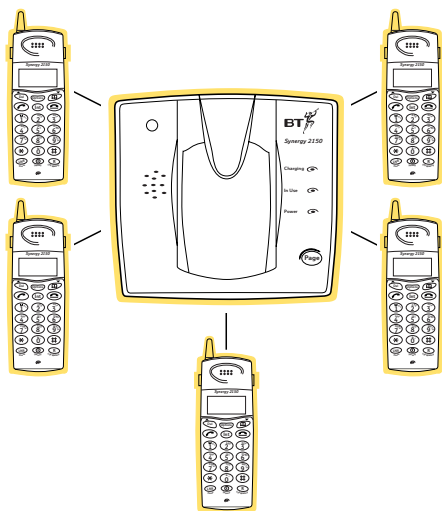

## Unpacking your Synergy 2150

If anything is missing, please contact your place of purchase immediately.

- Synergy 2150 handset.



- Synergy 2150 base station.



- Handset Battery pack.

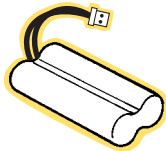

- Plug mounted, 13 amp mains adaptor.



- Telephone line cord



- Belt clip



## For your records

Date of purchase:

Place of purchase:

Serial number (on the underside of telephone base):

Purchase price:

For warranty purposes, proof of purchase is required, so please keep your receipt.

Enter your Base Station PIN here

--	--	--	--

See pages 12 and 38 for more information.

Enter your remote access security PIN code here.

--	--	--	--

See page 26 for more information.

# Safety instructions



Use only the approved battery pack supplied. Spare batteries – Item Code: 871996 are available from BT Shops and the Synergy Helpline **0845 602 1041**.

Do not try to use any other power supply except the one provided, otherwise you may permanently damage your Synergy 2150. It may also invalidate approval of this apparatus. To get a replacement Synergy 2150 base station power supply unit – Item Code 872073 – contact the Synergy Helpline **0845 602 1041**.



There is a slight chance your phone could be damaged by an electrical storm. We recommend that you unplug your Synergy 2150 from the mains power and telephone socket during storms.



The Synergy 2150 will produce a certain amount of heat during operation. Equally, the handset as well as any additional chargers you purchase can also become warm during charging. We advise against placing these products on antique, veneered or wooden surfaces as damage may occur.



Do not use the Synergy 2150 in damp, humid conditions such as bathrooms. Do not expose the equipment or batteries to fire and water.



Do not dispose of used batteries with general household rubbish and do not burn them.



Do not use the handsets in places where there are explosive hazards.



If you wear a hearing aid, please note that the Synergy 2150 works by sending radio signals between the base station and handset. These signals can interfere with hearing aids, causing a humming noise.

We advise that this product should not be used near emergency intensive care medical equipment and should not be used by individuals with pacemakers.

Synergy 2150 can interfere with other electrical equipment, e.g. answering machines, TV and radio sets, clock radio/alarms and computers if placed too close. It is recommended that you place your Synergy 2150 at least one metre away from such appliances to minimise any risk of interference.

Make sure you connect the power and telephone lines to the correct sockets in the base station.

Clean the handset and base station with a damp (not wet) cloth or antistatic wipe. Never use a dry cloth as this may cause a static shock. Never spray cleaning fluid directly onto the telephone.

# Setting up

Follow these steps to set up your Synergy 2150 ready for use.

## Plan the location of your Synergy 2150

Your Synergy 2150 works by sending and receiving radio signals between the base station and the handset.

The strength of the signal can depend on where you site the base station. Generally, the higher the base station is located the better. An upstairs room is ideal.

The following points should be considered:

- It should be within 3 metres of a power socket and phone socket otherwise extension cables will be required.
- Try to avoid locations near metallic obstructions or electrical appliances, such as TV sets, fridges, computers, fluorescent lights, radiators, metal pipes and metal window frames.

### Please note

*The Synergy 2150 has a range of up to 300 metres outdoors and up to 50 metres indoors. It is possible that the range may be affected by being near water (e.g. large ponds, lakes and the sea) as well as large metal objects (e.g. radiators, metal partition walls and steel girders).*

## 1 Connect the power cable

Plug the power cable into the power socket on your Synergy base station.

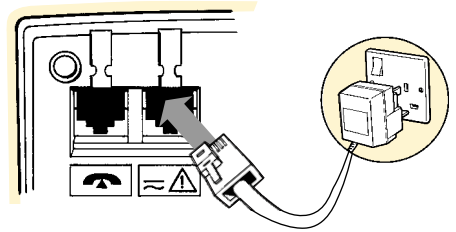

Plug the adaptor into the mains power supply and switch on. The power light comes on and starts to flash. This will continue flashing until the Day & Time are set (*see page 22*).

## 2 Install the rechargeable battery in the handset

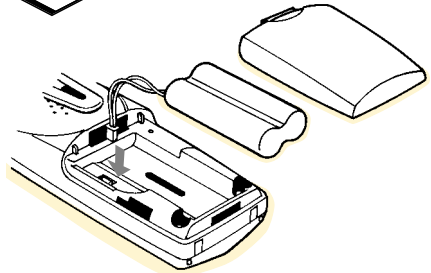

The Synergy 2150 uses a nickel metal hydride (NiMH) battery pack supplied. Take care to connect the battery as shown and replace the battery cover.

### 3 Charge the handset battery for at least 16 hours

Before you use your Synergy 2150 for the first time, it is important to have the handset battery fully charged. We recommend that you leave the Synergy 2150 on charge for at least 16 hours.

Place the handset on the base. The red charging light comes on. The handset should come pre-registered to the base station as H51 and this is shown in the top right corner of the display.

The battery symbol is also shown. It flashes during charging. Once the handset is fully charged, the display shows a full battery symbol.

#### Battery levels

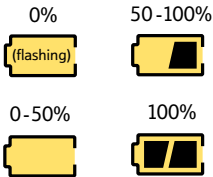

#### Battery low warning.

If the handset battery symbol is empty and flashing, and you hear a warning beep every 10 seconds, you will need to recharge your handset before you can use it.

#### Battery performance

To keep your battery in the best condition, leave the handset off the base station for a few hours at a time (after the initial 16 hour charge).

After charging your Synergy handset for the first time, subsequent charging time for the battery is approximately 4-5 hours. Battery and case may become warm during charging. This is normal and not dangerous.

**Note:** Once the handset is fully charged the red charging light will go off.

Under ideal conditions, the handset battery should give about 12 hours talktime (7 hours in handsfree mode) or 150 hours standby on a single charge.

Please note, however, that a new NiMH battery does not reach its full capacity until it has been in normal use for several days.

Please note that while the NiMH rechargeable battery can be expected to give years of service they do not last forever.

Their actual lifespan depends on how heavily they are used but over time, their capacity to recharge will begin to diminish and they will eventually need replacing.



**4** Connect the telephone line cord to the Synergy 2150 base station

Plug the line cord into the line socket on your Synergy base station.

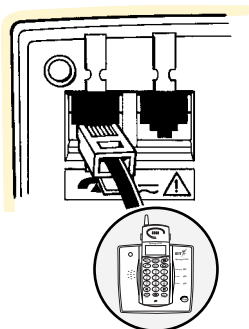

**5** Connect the telephone line cord

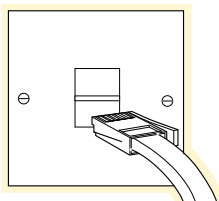

If you do not have modern phone sockets, call **Freefone 0800 800 150** and ask for a BT engineer to come and fit the correct type. This is a chargeable service.

---

*Your Synergy is now ready for use.*

---

**Pre-set PINs**

Your Synergy 2150 comes with a pre-set PIN which you will need to use to perform various functions on your phone.

Base station PIN is 0000 – used when adjusting base station settings and registration of new handsets.

**Customer Helpline**

**0845 602 1041**

# Using your Synergy 2150 telephone

## To switch your handset ON and OFF

*Press buttons in the order shown*



Press and hold the **POWER** button until the display goes blank. The handset is now off.



Press the **POWER** button again. You hear two beeps. The display flashes **Searching** and then shows the standby screen.

## To lock and unlock the keypad

This prevents you from accidentally operating the handset when you are carrying it around.



Press and release the **POWER** button. Display shows **Keypad-lock**.



Press the **POWER** button again to unlock the keypad.

## Please note

*It is not possible to make emergency calls when the keypad lock is on.*

## Making and receiving calls

### To make a call



Press the green **TALK** button. Display shows . You hear the dial tone.

**DIAL**

Enter the number you want and it is dialled.

*Or*

To preview the number before you call.

**DIAL**

Enter the number you want. It is shown on the screen but not dialled. If you make a mistake, you can change the number by pressing the **DEL** button to delete individual digits.



Press the **TALK** button to dial the number.

### To end a call



Press the red **END** button.  
*Or*

Place the handset back on the base.

## Call monitoring

If you would like to listen to your caller on the handset but allow others to hear the call, you could turn the base loudspeaker speaker on.

Make your call and ensure that the **L** is displayed on the handset.

 Options

Display will flash Loudspeaker.

 Options

Press the **OPTIONS** button to confirm.

Display will show Volume 0 1 2 3. **0** is off, **3** is loud.



Select the volume. (Settings always start at 2.)

 Options

Press the **OPTIONS** button to confirm.

## Caller display

The Synergy 2150 can let you know who's calling before you answer the telephone.

With BT's Caller Display service, your Synergy base station receives caller information which is transmitted over the BT network, for more information, see *page 31*.

## To receive a call

When the phone rings: the screen shows **External** (without Caller Display).



Press the **TALK** button to answer the call

*Or*

If the handset is on the base, simply pick it up and talk.

## To use handsfree

This function lets you keep your hands free, for example, to take notes, or to dial a number. It also enables others in the same room to hear and join in the call.



Press to get a line.

When making your call the **L** is displayed on the handset. This has then established start of dialling.



Press and hold for 1 second.

The handset loudspeaker symbol  will be displayed. You will now hear ringing or your caller on the handset speaker.



To change the volume. Display will show Volume 1 2 3. The number flashing is the current setting



Use to adjust the level, 1 is quiet, 3 is loud.

 Options

To confirm.



*To switch off:*

Press and hold for 1 second.

The loudspeaker symbol  will disappear from the display.



Press to end the call.

**To adjust the earpiece volume**

During a call you can adjust the volume of the handset receiver.



Press the **UP** and **DOWN** arrow buttons.

Display will show VOLUME 1 2 3.

The number flashing is the current setting.



Use the **UP** and **DOWN** arrow buttons until the display flashes at the desired volume level.



To confirm level.

**Please note**

*Once you have adjusted the earpiece volume, to use other functions during a call you must be out of earpiece volume control.*

*The handset automatically times out after approx 8 seconds, or press the **OPTIONS** button to confirm level.*

**Secrecy**

This lets you talk to someone else close by without your caller hearing the conversation.

During your call:



Press the **SECURITY** button. Display shows **Mute** and . Your caller cannot hear you.



To talk to your caller again.

**To redial the last number**



The last number called is displayed.



To dial the number.

**To redial one of the last 5 numbers**



The last number called is displayed.



To scroll through the last 5 numbers. (Or keep pressing the **REDIAL** button).



To dial the number displayed.

## Dialling mode

Your Synergy 2150 is preset to TONE dialling which most modern exchanges use. On some older exchanges or PBX's it may be necessary to change the dialling mode to PULSE.

Options



Until the display flashes BASE SETTING.

Options

**PIN**

Enter the 4-digit base station PIN. Original setting 0000.

Options



Until the display flashes DIAL MODE.

Options



Until the display flashes PULSE.

Options

To confirm.

## Go to Tone

If you are in the PULSE dialling mode then certain services accessed by tone dialling are not available.

During the call you can change to TONE by pressing the **OPTIONS** button.

Options



Use the **UP** and **DOWN** arrows to scroll to the Go to Tone command and press the **OPTIONS** button.

Options

Operation of your keypad after this will now be in TONE mode. When the call is completed you will revert to PULSE dialling.

## Go back

If during a call you have selected a function using the **OPTIONS** button, you can revert back to a normal display without losing the caller if you select the option Go back.

Options



Use the **UP** and **DOWN** arrows to scroll to the Go Back command and press the **OPTIONS** button to confirm.

Options

## To use the recall button

This is used when connected to certain switchboards and for some BT Select Services or those services available via your network provider. Refer to page 31 for more details.

Time break recall (TBR) is the method by which the exchange/PBX can be contacted and this is operated by the **R** (recall) button on the handset.

Your Synergy 2150 recall period is normally set to 100mS under the base setting menu **Flash time**. It should not normally be necessary to alter this value for use in the UK.





*To exit the options menu at any time, press the **END** button  until the display returns to standby.*

## Using the notepad

You can store a telephone number in your Synergy 2150 notepad memory during a conversation.

### To store a notepad number

 Press the **OPTIONS** button.

 Until the display flashes **Notepad**.

 The current notepad number (if any) will be displayed.

**KEYPAD** Enter the number you want to store. This will overwrite any existing number.

 To save the number.

### To view and dial a notepad number

 Press the **OPTIONS** button.

 Until the display flashes **Notepad**.

 Press the **OPTIONS** button.

 Until the display flashes **View**.

 The notepad number is displayed.

 To dial the number, if required.

## To store a notepad number in the phonebook

You must include a name to go with the number.

Options



Until the display flashes **Notepad**.

Options



Until the display flashes **Save**.

Options

**ABC**

Use the keypad to enter the name you want.

Options

The number is stored in the phonebook.

### Using the keypad to enter a name.

For example, to enter the name ANNE:

**2ABC**

Press once to enter **A**.  
Each time you have entered a letter wait for the cursor to move to the next space.

**6MNO**

Press twice to enter **N**.

**6MNO**

Press twice to enter **N**.

**3DEF**

Press twice to enter **E**.

**1**

To insert a space.

**0**

To insert '&'.



If you make a mistake, press the **DEL** button to delete the previous character or press the **END** button.



## Using the phonebook

You can store up to 20 of your most important or frequently dialled numbers in your Synergy's phonebook.

Stored numbers can be up to 25 digits long and each one must have a name allocated to it. The maximum number of characters in the name field is 12.

To ensure that the Caller Display facility operates correctly you should always enter the full telephone number into the phone book, including the area code, for example *0845602641*.

All entries in the phonebook are listed in alphabetical order.

*To exit the options menu at any time, press the  button until the display returns to standby.*

## To store a name and number in the phonebook

**Options**

Press the **OPTIONS** button.

**Del**

Until the display shows  
Phone book.

**Options**

**Del**

Until the display shows  
New entry.

**Options**

Display shows Name:.

**ABC**

Use the keypad to enter the  
name you want.

**2ABC**

For example, to enter the  
name ANNE:

Press once to enter **A**.  
Each time you have entered  
a letter wait for the cursor  
to move to the next space.

**6MNO**

Press three times to enter **N**.

**6MNO**

Press twice to enter **N**.

**3DEF**

Press twice to enter **E**.

**1**

To insert a space.

**0**

To insert '&'.

**Del**

If you make a mistake,  
press the **DEL** button to  
delete the previous  
character.

**Options**

Display shows  
Tel. number:.

**KEYPAD**

Enter the telephone number  
you want to store.

**Options**

To confirm. You can now  
store another entry.

## To enter a pause in a stored number

**LNR**  
Pause

When storing the number,  
press the **REDIAL/PAUSE**  
button at the point where you  
want to enter the Pause.

## To edit an entry in the phonebook

**Options**

Press the **OPTIONS** button.

**Del**

Until the display shows  
Phone book.

**Options**

**Del**

Until the display shows  
Change entry.

**Options**

**Del**

Until the display shows the  
entry you want to change.

**Options**

The name flashes.

**ABC**

If required, enter a new name  
to change it.

**Options**

To confirm the name.  
Display shows the phone  
number.

**KEYPAD**

If required, enter a new  
number to change it.

**Options**

To confirm the change.



### To dial a number stored in the phonebook



The first entry is displayed.



Press to scroll through the entries until the one you want is displayed.



To dial the number.

### To delete an entry from the phonebook



Press the **OPTIONS** button.



Until the display flashes Phone book.



Until the display shows Delete entry.



Until the entry you want to delete flashes.



To confirm deletion.

### To delete all entries from the phonebook



Press the **OPTIONS** button.



Until the display flashes Phone book.



Until the display flashes Delete all.



Delete all?.



To confirm deletion.

*Or*



To exit without deleting.

# Using your Synergy 2150 answering machine

As soon as the base station is connected and fully charged, your answering machine is ready for use.

It comes with a pre-recorded answer/record announcement: *"Hello, your call cannot be taken at the moment, so please leave your message after the tone"*. You can use this announcement or record one of your own (see page 24).

As well as recording incoming messages your Synergy 2150 can record memos for other users (see page 28) and allows you to skip through or delete your messages.

You can access your messages from any Synergy 2100 Additional handset or any external TouchTone telephone.

You will need to set the day and time so that you will know when each message was received.

## To set the base speaker volume

 Options

Press to open the main menu.

 Del Mute

Press until the display flashes TAM settings.

 Options

Press the **OPTIONS** button to confirm. Waiting will flash for one second and then Speaker will flash.

 Options

Press to confirm Speaker

 Del Mute

Use to adjust the volume. 0 is off, 3 is loud.

 Options

To confirm. You will then hear the confirmation beeps.

### Please note

*It is important to set the Day and Time in preparation for using your answering machine.*

### Please note

*If your Synergy 2150 is disconnected from the power, for example during a power cut, when power is restored the display will show Searching... followed by the idle screen and the green power light on the base will flash.*

*You will not have lost your messages but you will need to set the day and time again.*

*Once this is completed the green power light on the base will no longer flash.*

### To set the day and time

 Options

Press to open the main menu.

 Del

Press the **UP** and **DOWN** arrows until the display flashes TAM Settings.

 Options

Press the **OPTIONS** button to confirm.

 Del

Press the **UP** and **DOWN** arrows until the display flashes Day/Time.

 Options

Press the **OPTIONS** button to confirm.

Display will show  
Day: 1234567  
Time: 00:00

 Del

Use to scroll through 1 Mon, 2 Tues, 3 Wed, 4 Thurs, 5 Fri, 6 Sat, 7 Sun or press the number on the keypad.

 Options

Press the **OPTIONS** button to confirm.

Enter the time using the 24 hour clock. So for 14:52 type **1452** on the keypad.

 Options

Press the **OPTIONS** button to confirm.

You will then hear the confirmation beeps.

## To select day/time prompts between messages

The day and time of a call is recorded when it is received. You can switch this on or off when you listen to your messages.

 Options

Press to open the main menu.

 Del 

Press until the display flashes TAM settings.

 Options

Press the **OPTIONS** button to confirm. Waiting will flash for one second and then Speaker will flash.

 Del 

Press until Verbal is flashing.

 Options

To confirm.

 Del 

To select ON or OFF. Your chosen option will flash. (★ indicates the current setting.)

 Options

Press the **OPTIONS** button to confirm.

## Setting the answer mode

Your Synergy 2150 has 2 answer modes.

### Ans/record

Your Synergy 2150 has a pre-set announcement that allows your caller to leave a message, however, you can record your own announcement if you wish, see page 24.

### Answer only

Your Synergy 2150 will play a pre-recorded announcement but will not allow your caller to leave a message. However, you can record your own announcement if you wish.

### Please note

An ★ beside one of the above indicates which mode the answering machine is currently in.

## To switch the answering machine on/off and to set the answer mode

 Options

Press to open the main menu.

 Del 

Press until the display flashes TAM settings.

 Options

Press the **OPTIONS** button to confirm. Waiting will flash for one second and then Speaker will flash.

 Del 

Press until the display flashes TAM mode.

 Options

Press to confirm.

 Del 

Press until your chosen option flashes, ie:-  
Ans/Record  
Ans Only  
Tam off.

 Options

Press to confirm. You will hear the confirmation beeps.

### Please note

 Indicates that the answering machine is on.

## To record your own announcement

You can record an announcement of up to 3 minutes long to invite your caller to leave a message. A typical announcement for Ans./Record for example may be: *“Hello, I cannot take your call at the moment, so please leave a message after the tone”*.

 Options

Press to open the main menu.

 Del 

Press until the display flashes TAM settings.

 Options

Press the **OPTIONS** button to confirm. Waitings will flash for one second and then Speaker will flash.

 Del 

Press until display flashes Announce.

 Options

Press the **OPTIONS** button to confirm.

 Del 

To select Ans./record or Answer only.

 Options

Press the **OPTIONS** button to confirm.

 Del 

Until change is displayed.

 Options

Press the **OPTIONS** button. You will then see Recording. You should record your message now.

 Stop  
6

Press to end recording.

Your message will then play back automatically.



Press to return to the menu.

## Please note

*If you are recording an announcement using handsfree , you should make the recording with the handset about 2 feet away from you for best results.*

## To delete an announcement

 Options

Press to open the main menu.

 Del 

Press until the display flashes TAM settings.

 Options

Press the **OPTIONS** button to confirm. Waitings will flash for one second and then Speaker will flash.

 Del 

Press until display flashes Announce.

 Options

Press the **OPTIONS** button to confirm.

 Del 

To select Ans./Record or Answer only.

 Options

Press the **OPTIONS** button to confirm.

 Del 

Until Delete is displayed.

 Options

Display shows Delete?

 Options

Press to delete the announcement.

*Or*



To exit and leave the current message saved.

## Please note

*Deleting your own announcement restores the original pre-recorded message.*

## To adjust the number of rings before incoming calls are answered

You can select the number of rings from 2, 4 or 6 before incoming calls are answered.

 Options

Press to open the main menu.

 Del 

Press until the display flashes TAM settings.

 Options

Press the **OPTIONS** button to confirm. **Waiting** will flash for one second and then **Speaker** will flash.

 Del 

Until **Rings counts** is flashing.

 Options

Press the **OPTIONS** button to confirm.

Display shows **Rings counts**  
2 4 6.

 Del 

Until the number of rings you want is flashing.

 Options

Press to confirm.

## Time saver

When the number of rings is set to 4, the Synergy 2150 will answer after 2 rings if new messages are left, and after 4 rings if there are no new messages. This is for use during remote access, see page 29,

## To adjust the base speaker volume

When listening to your messages:

 Options

Press the **OPTIONS** button until display shows **Volume**  
0 1 2 3.

 Del 

To select the volume. 0 is off, 1 is quiet and 3 is loud.

 Options

Press the **OPTIONS** button to confirm.

## To turn the handset speaker on or off

When listening to your messages:



Press for 1 second.

The  indicates that the loudspeaker is on.

If it is missing then the loudspeaker is off.

## To adjust the handset speaker volume

When listening to your messages:



Display shows **Volume 1 2 3.**



To select the volume. 1 is quiet and 3 is loud.



Press the **OPTIONS** button to confirm.

## To set your security PIN for remote access



Press the **OPTIONS** button.



Until display flashes **TAM Settings.**



Press the **OPTIONS** button to confirm.

Display will show **Waiting** for 1 second then **Speaker** will flash.



Until display flashes **Remote PIN.**



Press the **OPTIONS** button to confirm.

Display shows **PIN XXXX (Your PIN.)**

Enter your new pin number.



Press the **OPTIONS** button to confirm.

Display flashes **Remote PIN.**



Press to return to the menu.

For information on how to use remote access, *see page 29.*

## Memory full

Your Synergy 2150 has up to minutes of recording time.

If a call arrives when the memory is full the display will show **Memory full** and the caller will hear that their message cannot be taken.

It is, therefore, advisable to delete your messages to create more space, *see page 28.*

## Message playback

The following table provides a guide to the possible message indications you may see on your Synergy 2150 in certain situations.

For example, if you have new messages and the answering machine is on you will see the flashing in the display, **NEW MSG** will be displayed on the LCD and the **In Use** light will flash on the base LED.

### Answer Machine Message indications

On/Off	Message status	Icon	LCD display	Base LED
ON	New messages	Flashing	New msg	Flashing
ON	Old messages	Flashing		
ON	No messages	Steady		
OFF	New messages	No icon	New msg	Flashing
OFF	Old messages	No icon		
OFF	No messages	No icon		

## To play your messages

Options

Press the **OPTIONS** button.



Until display flashes **Message**.

Options

Press the **OPTIONS** button to confirm.

Waiting will be displayed for one second and then:



New is the number of new messages received.

TOT is the total number of old and new messages.

LSP is the current base speaker setting.

The loudspeaker icon  indicates that the handset loudspeaker is on.

Options

Press the **OPTIONS** button

The display flashes **Play**.

Options

Press the **OPTIONS** button to confirm and play your messages.

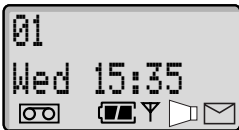

This shows that message number one was recorded on Wednesday at 15.35 and is being played.

If you have selected **Verbal on** then you will hear the day and time of your messages.

Your messages will continue until all new messages have been played.

## To skip, play, pause and delete your messages

When listening to your messages use these buttons:



Press once to go to the start of the current message. Press twice to go back to the previous message.



Play/pause. During pause display will show **Pause...**



Skip to the next message.



Delete the current message on an individual basis.



Record a memo.



Stop.



## To delete old messages

If you want to delete all of your messages:

 Options

Press the **OPTIONS** button.

Display will flash **Message**.

 Options

Press the **OPTIONS** button to confirm.

**Waiting** will be displayed for 1 second.

 Options

Press the **OPTIONS** button.

Display will flash **Play**.

 Del 

Until display flashes **Delete old**.

 Options

Press the **OPTIONS** button to confirm.

Display will show **Delete old?**

 Options

To delete the messages.

*Or*



To revert to the previous menu and *not* delete.

## To record a memo

You can record a memo up to 3 minutes long that can be played back as a normal message.

 Options

Press the **OPTIONS** button

Display will flash **Message**.

 Options

Press the **OPTIONS** button to confirm.

Display will flash **Waiting**.

 Options

Press the **OPTIONS** button to confirm.

Display will flash **Play**.



Until display flashes **Memo**.

 Options

Press the **OPTIONS** button to confirm.

**Recording...** is displayed and you will hear a long beep. You can now start recording your memo.



Press when you have finished recording.

## To use Call Screening

You can let your Synergy 2150 answer an incoming call and hear the caller through the handset speaker. You can then decide whether to take the call.

 Options

Whilst the TAM is recording.

Display shows **Call Screen**.

 Options

Press the **OPTIONS** button to confirm.

Display shows **Screen**.

You will hear who is calling.



To end screening.

## Remote access

You can switch on and operate your answering machine from any other TouchTone telephone to play your messages and memos.

To keep your messages private, you will need to enter your 4-digit security PIN code before you can access your messages.

The pre-set security code is 0000 but it is advisable to change this, *see page 26* to change your security code.

You can keep a record of the new number in the box printed in the front of this guide.

### Time Saver

If you have your ring count set to 4 rings, then you can tell if you have any new messages before the machine answers.

If the machine answers after 2 rings then you know you have new messages. If it gets to 3 rings, then you know there are no new messages and you can hang up, saving you the cost of a call.

### To turn answering machine on via remote access

Call your phone.

After approx. 16 rings, the telephone answer machine will answer and announce "*Answer off*".



Press the ★ button.

**PIN**

You will be prompted to add your security code e.g. 0000.

You will hear "*To play all messages, press 2*".



To switch on the answer machine in answer record mode, press the **8** button.



To switch on the answer machine in answer only mode, press the **9** button.

## Remote access quick guide

To listen to your messages remotely from an external telephone.



Call your answer machine and as you listen to the announcement press ✱.

When prompted, enter your remote access security PIN e.g. 0000.

If you incorrectly enter your security PIN three times you will be disconnected.

1

Press once to go to the start of the current message.  
Press twice to go back to the previous message.

2

Play/ pause. During pause display will show PAUSE...

3

Skip to the next message.

4

Delete the current message.

5

Record a memo or announcement.

2

To select Memo.

8

To select Ans./record.

6

Stop.

9

To select Answer only.

7

Turn the Synergy 2150 off.

8

To select Ans./record.

9

To select Answer only.

# BT Select Services

If you are connected to a digital exchange, you can subscribe to a range of BT Select Services. If you wish to subscribe to any of these services contact us on **Freefone 0800 800 152** business, **150** residential, 8am to 6pm, Monday to Friday.

## Using Caller Display

If you have subscribed to your network provider's Caller Display service you will be able to see the caller's number on the display (provided it is not withheld) prior to answering a call.

If you have not subscribed to Caller Display then please contact your network provider for details.

If a call is received and you have stored a name and number into your phonebook (*see page 19*) you will see both the name and number and your screen will look like this:

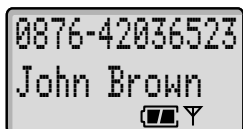

### Please note

*Caller Display information will ONLY be saved if the call has NOT been answered, or if the answering machine has taken the call.*

*Caller Display information will not be saved into the Call Log if the call has been answered.*

The following table provides a guide to the call indications you may see on your Synergy 2150.

For example, if you have a new call the  icon will be flashing on the display, **NEW CALL** will be displayed on the LCD (unless there are new messages when **NEW MSG** is shown) and the **In Use** light will flash on the base LED.

### Call indications

Call status	Icon 	LCD display	Base LED
New calls	Flashing	New call	Flashing
Old calls	Steady		
No calls old or new	No icon		

### Please note

*If there are both new messages and new calls, **NEW MSG** will be shown on the display.*

## Please note

*If someone has called several times only the last day and time will be recorded. The number of times the caller has tried to contact you will be shown on the right side of the screen.*

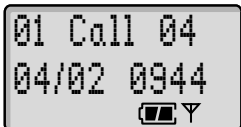

## To view stored numbers

Options

Press the **OPTIONS** button.



Until display flashes  
Caller ID.

Options

Press the **OPTIONS** button  
to confirm.

Display will flash **Waiting**  
for 1 second and then **View**  
will flash.

Options

Press the **OPTIONS** button  
to confirm.

The screen will show how  
many numbers have been  
stored.

**NOTE:** If no calls have been  
received the screen will say  
**Data Empty.**

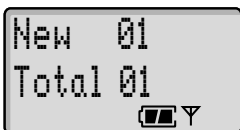

Options

The first caller will be  
displayed.



Use to scroll through the  
calls.

Options

Press to show the day and  
time of the call.

Up to 30 numbers can be  
stored in this way.

## Please note

*If a call is not answered, by the answering machine or by a person, the number will be stored in the memory with the time and date of the call.*

## To save a caller's number into the phone book

When viewing your stored  
numbers:

Options

To see the time and date of  
the call.

Options

Display will flash **Save.**

Options

To confirm.

Display will show **Name:**  
and the telephone number.

**ABC**

Enter the caller's name.

Options

To confirm. You will then  
hear the confirmation beeps.

## To delete old numbers

 Options

 Del 

Until display flashes  
Caller ID.

 Options

To confirm.

Display will flash **Waiting**  
for 1 second and then **View**  
will flash.

 Del 

Until display flashes  
**Delete old**.

 Options

To confirm.

Display shows **Delete old?**

 Options

To delete.

*Or*



To cancel and return to the  
menu without deleting the  
numbers.

## Using the VIP feature

This feature allows you to store two important numbers as VIPs. These could be, for example, your partner's mobile number, a family or friend's number.

Used with Caller Display, when a VIP rings a different ring tone will be heard, alerting you that one of your VIPs is calling and their number will be displayed.

## To store a VIP number

 Options

Press the **OPTIONS** button.

 Del 

Press until **Caller ID** is  
flashing.

 Options

Press the **OPTIONS** button.

 Del 

Press until **VIP** is flashing.

 Options

Press the **OPTIONS** button.

 Del 

Press until **VIP 1** is flashing.

 Options

Press the **OPTIONS** button.

**123**

Enter the telephone number.

 Options

Follow exactly the same  
procedure for **VIP 2**.

## Call Waiting

If an incoming call arrives while you are already engaged on a telephone call, you will hear a soft beep every 5 seconds (this beep is not audible to the person you are speaking to).

Instead of the engaged tone, the second caller will hear an announcement to hold on as you are aware that there is a second call.

## To use Call Waiting



You can answer the second call, without disconnecting your first caller, by pressing the **CALL WAITING** button. The first caller will be put on hold.



When you have spoken to the second caller you can return to the first caller by pressing the **CALL WAITING** button again. You can switch back and forth between the two calls without disconnecting either if you wish.



If you wish to disconnect the first call press the **END** button after speaking to the first caller.



The handset will then ring. Press the **TALK** button again and continue with the second caller.

The second caller will only be charged for their call from the moment you answer and not while they are waiting for your initial contact.

## Other services

- Call my bill
- Call Barring
- Call Diversion
- Charge Advice
- Reminder Calls
- Three-way Calling
- Call Return 1471

For more information about these Select Services, call BT on **Freefone 0800 800 150** for residential or **152** for business. If you are not on the BT network, please ask your telecommunications supplier for information on their services.

# Optional Settings

## To adjust the handset ringer volume

The volume levels range from **0-5** where **0** is off and **5** = maximum. The pre-set level is **3**.

You can also set the handset to ring at different volumes for external calls and internal calls (i.e. calls from other handsets registered to the base station).

Options

Press the **OPTIONS** button.



Until display flashes  
HS settings.

Options

Press the **OPTIONS** button



To select either **Ext. ringer** (to set the ring volume for external calls) or **Int. ringer** (to set the ring volume for internal calls).

Options

Press the **OPTIONS** button



Until the display flashes  
Volume.

Options

Press the **OPTIONS** button



To hear and switch between  
volume settings **0-5**.

Options

To confirm the setting  
displayed.

To exit the options menu at any time, press the **END** button  until the display returns to standby.

## To adjust the handset ringer melody

You can choose from 6 melodies. The pre-set melody is **4**.

You can also set different melodies for external calls and internal calls (i.e. calls from other handsets registered to the base station)

Options

Press the **OPTIONS** button.



Until display flashes  
HS settings.

Options

Press the **OPTIONS** button  
to confirm.



To select either **Ext. ringer** (to set the ring melody for external calls) or **Int. ringer** (to set the ring melody for internal calls).

Options

Press the **OPTIONS** button.



Until the display flashes  
Melody.

Options

Press the **OPTIONS** button  
to confirm.





To hear and switch between the different melodies **1-6**.

**Options**

Press the **OPTIONS** button to confirm the setting displayed.

### To switch the keytones off and on

When you press a button on the handset, you hear a beep. You can switch these beeps off.

**Options**



Until the display flashes **HS settings**.

**Options**



Until the display flashes **Key tone**.

**Options**



Until the display flashes **ON** or **OFF**.

**Options**

To confirm the setting displayed.

### To set a different language for the display

You can set the options of 'English', 'Français', 'Deutsch', 'Italiano' or 'Español'.

**Options**



Until the display flashes **HS settings**.

**Options**



Until the display flashes **Language**.

**Options**



To scroll through the options, **Deutsch**, **English**, **Français**, **Italiano** or **Español** until the required language flashes.

#### Please note

*The current language setting is indicated by an ★ before the country's language.*

**Options**

To select the language displayed.

# Base station settings

## To adjust the base ringer melody

You can use your handset to change the melody.

Options



Until the display flashes  
Base settings.

Options

**PIN**

Enter the 4-digit base station  
PIN. Original setting 0000.

Options



Until the display flashes  
Base ringer.

Options



Until the display flashes  
Melody.

Options



To hear and select the choice  
of melody you want **1-6**.  
The original setting is **4**.

Options

To confirm the selection  
displayed. You hear a  
confirmation ring.

## To adjust the base ringer volume

You can use your handset  
to change the volume.  
The settings range from  
**0-5**, where **0** = off and  
**5** = maximum.

Options



Until the display flashes  
Base settings.

Options

**PIN**

Enter the 4-digit base station  
PIN. Original setting 0000.

Options



Until the display flashes  
Base ringer.

Options



Until the display flashes  
Volume.

Options



To hear and select the volume  
you want **0-5**. The original  
setting is **3**.

Options

To confirm the selection  
displayed. You hear a  
confirmation ring.

## To set the handset priority

If you are using more than one handset on your base station, you can select one handset to ring before all the others. You can then set the number of rings it will make before the other handsets start ringing.

Options

Del

Until the display flashes  
Base settings.

Options

**PIN**

Enter the 4-digit base station PIN. Original setting 0000.

Options

Del

To scroll through and select  
HS Priority.

Options

Del

To confirm.

Options

Del

To scroll through the options:  
No Priority - all handsets ring at the same time.  
Handset 1-5 - the selected handset rings first.

Options

To confirm the displayed setting. Display flashes  
Ring (1-99).

**KEYPAD**

Enter the number of rings you want the selected handset to ring before the other handsets.

Options

To confirm.

## To change the base station PIN

If you change your base station PIN, keep a record of the new number by writing it in the space provided on page 8.

Options

Del

Until the display flashes  
Base settings.

Options

**PIN**

Enter the 4-digit base station PIN. Original setting 0000.

Options

Del

Until the display flashes  
Change PIN.

Options

**PIN**

Enter the new 4-digit PIN you want.

Options

To confirm new PIN. Display shows Retype.

**PIN**

Re-enter the new PIN.

Options

To confirm the setting.

## To set call barring

You can bar calls with up to five different prefixes, making it impossible to dial out if a telephone number is preceded by one of these prefixes. This could be an international dialling code or a premium rate service. You can also specify individual handsets on which you want to set call barring.

Options

Del

Until the display flashes **Base settings**.

Options

**PIN**

Enter the 4-digit base station PIN. Original setting 0000.

Options

Del

Until the display flashes **Call barring**.

Options

**KEYPAD**

Enter the prefix number to be barred. (If you are barring international calls, enter **00**).

Options

Display shows **HS**.

**KEYPAD**

Enter the handset number(s) **1-5** you want calls to be barred from.

Options

To confirm. You hear a confirmation ring.

Repeat the steps above to enter up to five separate barred prefixes.

## To select which base station you want your handset to use

Options

Del

Until the display shows **Select base**.

Options

Del

To scroll through the options: **Best base** = your handset will automatically select the base station with the strongest reception.

**Base 1-4** = you can select a specific base to use.

Options

To confirm.

## To display the base station name on your handset

Your handset can display the name of the base station to which it is currently registered.

Options

Del

Until the display shows **Show base**.

Options

Del

Until the display shows **Base name**.

Options

Del

Until the display shows **ON**.

Options

To confirm the setting.

## To change the base station name

If you choose to display the base station name on your handset (see above), you can give each base a different name. For example, 'Office' or 'Home'.

Options



Until the display shows  
Show base.

Options



Until the display shows  
Set new name.

Options



Until the base name you wish  
to change is flashed on the  
display.

Options

**ABC**

Use the keypad to enter the  
new base station name.

Options

To confirm the setting.

*See page 18* for details of  
how to enter letters.

# Using additional handsets

Registering an additional Synergy handset with the base station or de-registering a handset.

As well as your original handset, you can register up to a further 4 additional handsets to your Synergy 2150 base station.

The system allows internal calls between two handsets while a third is making an external call.

Each additional handset you purchase must be registered with the base station.

## Please note

*Remember to charge the batteries of new handsets for at least 16 hours. When switched on, a new additional handset will display Not SUB. This tells you that the handset is not yet registered with the base station.*

## To register a handset

Page

*At the base station:*

Press the **PAGE** button and hold for at least 10 seconds, until you hear the validation tone, then release the button.

The Ir Use LED on the base will flash repeatedly. You must register the handset in the next 10 minutes.

*At the handset:*

Options



Until the display flashes **Registration**.

Options



Press to display the available base station names **BASE 1-4**.

If your handset is already registered to another base, then the display shows **★** next to the base name.

Options

When a free base station number is displayed. Display then shows **Searching** and the base station number.

When the handset has detected the base station signal, it gives a confirmation ring. You are asked to enter the base station PIN.

**PIN**

Enter the 4-digit base station PIN. The pre-set PIN is **0000**. (To change the PIN, see page 38.)

Options

The LED will stop flashing (unless there are new messages).

The display shows the normal standby setting when the registration process is completed.

The handset is automatically registered with the next available handset number. This number is shown on the display as HS 2, 3, 4 or 5.

### Please note

*If the registration process fails, the handset display shows Not SUB and you should begin the process again.*

### To de-register a handset

*Press buttons in the order shown*

You can use your handset to de-register another handset from a base station. You cannot de-register the handset you are using from the base station you are using.

Options



Until display flashes **Base settings**.

Options

**PIN**

Enter the 4-digit base station PIN, the pre-set PIN is 0000.

Options



Until the display shows **Remove HS**.

Options



Until the handset number you want to de-register is flashing.

Options

To confirm.

You will hear a confirmation tone and the display will return to **Remove HS**.

### To call another handset

Int

Press the **INT** button. Display shows the INT symbol and Internal.

Enter the handset number you want. Display shows the number and the called handset rings.



Press the **END** button to end the call.

### To transfer an external call to another handset

Int

Your caller is put on hold and you hear the dialling tone.

KEYPAD

Enter the handset number to which you want to transfer the call. When the handset is answered



The call is transferred.

If the handset is not answered, press the **INT** button to speak to the caller again.

## To hold a three-way conversation

You can talk to one external call and another internal caller at the same time on your Synergy handset.

During a call with an external caller:

Int

Your caller is put on hold and you hear a tone.

KEYPAD

Enter the handset number to which you want to transfer the call. When the handset is answered.

#

Press and hold the # button for a few seconds until the display clears. You can now start your three-way conversations.



# Operating with additional base stations

You can use up to five handsets on each Synergy 2150 base station, and up to four base stations with your handset to build up a comprehensive cordless telephone system.

The handset supplied with each base station is already registered as HS1.

## To register your handset to another base station

You can register a handset with up to 3 other base stations.

Follow the same steps shown on page 41, ensuring that you select a base station that is free i.e. one that has no ★ against it.

Page

Press and hold the **PAGE** button on the base station you want to register your handset to. It sends a unique signal and your handset will automatically accept it as the next base station.

To avoid confusion you may wish to allocate a different name from your original base. This can be done by following the steps on page 40.

In this way when selecting your base station to operate from, the handset will automatically display your new base name, once it has established connection, e.g. name **Base 1** as Home and **Base 2** as Office.

## Please note

*When registering handsets to another manufacturer's base, the assigned handset number may not appear in the handset display.*

*To find out the handset number, press **INT** then 1 to call handset 1. Then look at the display on handset 1 to see your handset number.*

# Connecting to a switchboard

When connecting your Synergy 2150 to a switchboard/PBX, you may need to change the dialling mode from TONE to PULSE.

## To change the dialling mode

The dialling mode is set to TONE when the product is supplied.

To change to PULSE.

Options



Until display flashes Base settings.

Options

**PIN**

Enter the 4-digit base station PIN. Original setting 0000.

Options



Until the display flashes Dial mode.

Options



Until the display flashes Pulse.

Options

To confirm setting.

## To change the network connection

When connected to some switchboards/PBX's you may encounter higher than normal speech levels. If this is the case you can alter the network setting from PSTN to PBX which would reduce the levels to normal.

Options



Until the display flashes Base settings.

Options

**PIN**

Enter the 4-digit base station PIN. Original setting 0000.

Options



Until the display flashes Network.

Options



Until PBX is flashing.

Options

To confirm the setting.

## To enter a PSTN pre-fix code

With some switchboards it may be helpful to dial a pause after entering the PSTN pre-fix code eg: 9,11 etc. to enable you to get an outside line. However, your Synergy 2150 can enter a pause automatically for you.

### Please note

*Each time you dial out on a PSTN number you must still dial the pre-fix code i.e. you will still have to dial the pre-fix code 9,11 etc. to enable an outside line to be established.*

*The numbers held in the directory must also have the PSTN pre-fix code to gain an outside line with some switchboards.*

### Please note

*Each time the PSTN pre-fix code is dialled a pause will automatically be inserted before the telephone number is dialled.*

Options



Until the display flashes  
Base settings.

Options

**PIN**

Enter the 4-digit base station  
PIN. Original setting 0000.

Options



Until the display flashes  
PSTN Prefix.

Options

**KEYPAD**

Enter the pre-fix number  
after which you want the  
pause to be inserted. This  
can be up to 5 digits.

Options

To confirm the setting.

# Maintenance

## General

Simply clean your Synergy 2150 with a damp cloth (not wet) or an antistatic wipe. Never use a dry cloth as this may cause a static shock.

## Service

### Within guarantee

If you experience a problem with your Synergy 2150 you should contact the Synergy Helpline on **0845 602 1041**. Calls are charged at local call rates. If the problem is not remedied, you will be advised to contact your original point of purchase.

Some retailers offer extended warranty schemes for cover outside the initial 12-month period. Please ask them for details.

### Outside warranty

If your Synergy 2150 needs repair after the warranty period has ended, contact the Synergy Helpline on **0845 602 1041** for information on our recommended repair agents.

## If you have to return your Synergy 2150

Pack the unit securely, preferably in the original packaging. All parts must be returned including the mains power adaptor. We cannot take responsibility for goods damaged in transit.

# Help

## Emergency calls

*The emergency services can be contacted in the UK by dialling **999** or **112** which is valid in any country that is a member of the European community.*

## Please note

*If your Synergy 2150 is connected to a switchboard/PBX, you may have to dial an access number before **999** to contact the emergency services. Some switchboards cannot dial out during a power failure.*

*The Synergy 2150 will not work when the power fails. Alternative arrangements should be made for access to emergency services.*

## Replacing the handset battery

After a time, you may find that the handset battery is running out of charge more quickly. This is a standard sign of wear and the battery will need replacing.

Spare batteries (Item Code 871996) are available from BT Shops or contact the Synergy 2150 Helpline **0845 602 1041**.

Do not immerse batteries in water or throw them into a fire, or dispose of them with ordinary domestic refuse.

BT accepts no responsibility for damage caused to your Synergy handset by using any other type of battery.

## No display appears

The battery may be flat or dead. Recharge or replace the battery.

## No dial tone

Is the telephone line cord plugged into the phone socket?

Check that the base station is connected to the mains power and switched on.

## You cannot link up with the base station

If the display shows Not SUB, the handset must be registered with the Synergy 2150 base station. See page 41.

Is the display flashing ∇ ?

The mains power cable may not be connected at the base or switched on.

Are you in range of the base station?

Battery could be low or flat.

If using more than one base station, check that you are connected to the correct base. See page 39.

## No ring on the handset or base station

The ringer volume may be switched to silent. To adjust the ringer volume on the handset, see page 35, on the base station, see page 37.

Check that that the base station is plugged into the phone socket.

Check that that the base station is plugged into the mains power and switched on.

**Buzzing noise on my radio, TV, computer or hearing aid**

Sometimes, your Synergy 2150 can interfere with other electrical equipment if it is placed too close.

It is recommended that you place your Synergy 2150 and other Synergy handsets at least one metre away from such appliances to avoid any risk of interference.

**The charger does not appear to be working**

*Check that:*

- the power adaptor is properly plugged in to the charger
- your handset has slotted correctly into the charger
- the battery is correctly fitted into the handset

Are you using the correct power adaptor?

Synergy 2150 base station power supply is Item Code 872073.

**Cannot adjust the option in the base station**

Is someone else making changes via another handset?

Have you pressed the **OPTIONS** button to confirm your selection?

If you are still experiencing difficulty, call the Synergy 2150 Helpline on **0845 602 1041**.

Have you pressed the **OPTIONS** button to confirm your selection?

*If you are still experiencing difficulty, call the Synergy 2150 Helpline*  
**0845 602 1041.**

**Please note**  
*In the event of a mains power failure, date/time stamp will need to be reset.*

# Technical information

## Environment

Your Synergy 2150 should be kept free of dust, moisture, high temperature, vibration and should not be exposed to direct sunlight. Do not stand it on carpets or other surfaces which generate fibres or place it in locations which prevent the free flow of air over its surfaces.

### Warning

*The apparatus is designed to be operated in a normal office or domestic environment where the relative humidity does not exceed 75%. It should not be used in bathrooms or near water.*

## If the power fails

Alternative arrangements should be made for access to emergency services.

## How many phones can you have?

All items of telephone equipment have a Ringer Equivalence Number (REN), which is used to calculate the number of items which may be connected to any one telephone line. The Synergy 2150 has a REN of 1. Any other instrument provided by BT may be assumed to have a REN of 1 unless otherwise stated. A total REN of 4 is allowed.

## Connection to the BT telephone network

Synergy 2150 is fully approved for connection to the BT network provided it is used according to the instructions in this guide. The telephone lines must provide Multi-frequency (Touch Tone) dialling capabilities.

It may be connected to Direct Exchange Lines and switchboards (PBXs) with new plan (plug and socket) arrangements.

## Connecting to switchboards

Synergy 2150 is only approved for use with a compatible switchboard including those which do not provide secondary proceed indication.

If you would like a list of suitable switchboards, contact BT on **154**.

If you do not have a compatible switchboard, it cannot be guaranteed that the product will operate correctly under all possible conditions of connection. If you have any difficulties, contact BT on **154**.

Generally, Synergy 2150 can be connected to any switchboard where a simple modern telephone can be used to make and receive calls. Synergy 2150 is suitable for connection to switchboards which return secondary proceed indication.

# Technical specification

<b>Standard</b>	DECT, GAP
<b>Number of channels</b>	120 duplex channels
<b>Radio frequency range</b>	1880 MHz to 1900 MHz
<b>Duplex method</b>	Time-division multiplexing. 10 ms frame length
<b>Channel spacing</b>	1728 kHz
<b>Bit rate</b>	1152 kbit/s
<b>Modulation</b>	GFSK
<b>Voice coding</b>	32 kbit/s
<b>Transmitted power</b>	10 mW, average output per channel
<b>Range</b>	Up to 300 metres outdoors (uninterrupted line of sight) Up to 50 metres in buildings
<b>Power supply</b>	Base station 230 V/50 Hz (AC adaptor)
<b>Power consumption base station</b>	3.6 VA
<b>Operating time, mobile unit (with fully charged battery)</b>	Standby: up to 150 hours Phone in use: Up to 12 hours Handsfree: Up to 7 hours talktime.
<b>Permitted ambient conditions for operation (maximum)</b>	0°C to 55°C – Handset; 5°C to 45°C Base; 15% to 90% rel. humidity
<b>Permitted storage temperature</b>	-10°C to +60°C
<b>Signalling method</b>	DTMF and PULSE
<b>Signal key function</b>	Timed Break Recall
<b>Base station dimensions</b>	120mm x 126mm x 60mm (L x W x H)
<b>Handset dimensions</b>	151mm x 46mm x 30mm (L x W x H)
<b>Weight</b>	Base station: 175g Handset: 115g (with battery)



# Index

<b>Answering machine</b>		
answer mode	23	
base speaker volume	21	
call monitoring	14	
call screening	28	
delete announcement	24	
delete old messages	28	
handset speaker on/off	25	
handset speaker volume	26	
memory full	26	
number of rings	25	
on/off	23	
play messages	27	
record memo	28	
record own announcement	24	
remote access	29	
save caller's number into phonebook	32	
security PIN	26	
select day/time prompts	23	
set day and time	22	
time saver	25, 29	
view stored numbers	32	
VIP feature	33	
<b>At a glance</b>	1, 2	
<b>Base station</b>		
additional	44	
change base station name	40	
handset display	39	
melody	37	
PIN number	12, 38	
priority, handset	38	
register handset	41	
ringer volume	37	
select which base station	39	
<b>Batteries</b>		
charging	11	
helpline	49	
installing	10	
levels	11	
low warning	11	
performance	11	
replacing	48	
<b>Building up a phone system</b>	7	
<b>Call barring</b>	39	
<b>Call monitoring</b>	14	
<b>Call screening</b>	28	
<b>Call waiting</b>	33	
<b>Caller display</b>	31	
<b>Calls</b>		
end	13	
handsfree	14	
make	13	
receive	14	
redial	15	
secrecy	15	
three-way calling	43	
transfer	42	
<b>Cleaning</b>	47	
<b>DECT</b>	7	
<b>Delete</b>		
announcement	24	
old messages	28	

old numbers	33	Mains adaptor	10
Dialling mode	16, 45	Maintenance	47
change	45	Make a call	13
pulse	16	Melody	
tone	16	base station	37
Display symbols	2	handset	35
<b>E</b> nd a call	13	Memory full	26
<b>G</b> o back option	16	Menu	3
Guarantee	47	<b>N</b> otepad	
<b>H</b> andset		dial a number	17
additional	41	store a number	17
call another handset	42	store in phonebook	18
de-register	42	view a number	17
display which base station	39	Number of rings	25
earpiece volume	15	<b>O</b> ptional settings	35
keytones	36	On/Off	
melody	35	answering machine	23
menu	3	handset	13
monitor	14	handset speaker	26
on/off	13	Pause	19
register	41	<b>P</b> honebook	18
ringer volume	35	delete	20
ringer priorities	38	delete all	20
three-way call	43	dial a number	20
transfer external call	42	edit an entry	19
transfer	42	pause	19
Handsfree	14	store a name and number	19
Help	48	Phone system – building up	7
Helpline	49	PIN	
<b>I</b> ntroduction	7	base station	12, 38
<b>K</b> ey features	5, 6	pre-set	12
Keypad lock/unlock	13	remote access	26
<b>L</b> anguage display	36	Play messages	27
Lock keypad	13	Power socket	10
Location	10		

Power cable	10	Tone dialling	16
<b>Recall</b>	16, 17	<b>Unpacking</b>	8
Receive a call	14	Unlock keypad	13
Record		<b>VIP</b>	33
memo	28	Volume	
own announcement	24	earpiece	15
Redial	15	handset ringer	35
Remote access	29	handset speaker volume	26
Remote access PIN	26	base station ringer	37
REN (Ringer Equivalence Number)	50	Warranty	47
Returning your Synergy 2150	47		
<b>Safety instructions</b>	9		
Secrecy	15		
Security PIN for remote access	26		
Select services	31		
caller display	31		
VIP feature	33		
call waiting	33		
Service	47		
Setting up	10		
Switchboard	45		
dialling mode	45		
connecting	45, 49		
PSTN pre-fix code	46		
Switch handset on/off	13		
<b>Technical information</b>	50		
Telephone socket	12		
Technical specification	51		
Telephone line cord	12		
Three-way conversation	43		
Time saver	25		



## Offices worldwide

The telecommunications services described in this publication are subject to availability and may be modified from time to time. Services and equipment are provided subject to British Telecommunications plc's respective standard conditions of contract. Nothing in this publication forms any part of any contract.

*Touchtone™* is a registered trade mark of British Telecommunications plc in the UK.

© British Telecommunications plc 2000.  
Registered Office: 81 Newgate Street, London EC1A 7AJ.  
Registered in England No. 1800000.  
Designed by: The Art & Design Partnership Limited.  
Printed in China. Synergy 2150. Issue 1 (5/00) 7

Printed on paper which meets international environmental standards.



CE compliant to 89/336/EEC  
(EMC Directive) & 73/23/EEC  
(Low Voltage Directive)

**APPROVED** for connection to  
telecommunication systems specified in  
the instructions for use subject to the  
conditions set out in them



**610384**