

Your BT3520 is now ready for use.

If you ever need to remove the batteries, simply slide open the battery compartment cover and using the finger grip the batteries and pull them out.

- Place the handset on the charger to charge for 24 hours. Remove the protective film from the handset screen and activate the batteries as shown above.
- For each additional handset and charger: plug the mains power adaptor (item code 066771) into the socket on the back of the charger, secure the cable behind the retaining clip and plug the other end into the mains wall socket and switch the power on.

Set up your additional handsets (multi-packs only)

Important: Charge the handset batteries for 24 hours or your phone may not work.



- Remove the protective film from the handset screen and the base lens and activate the batteries by pulling the plastic tab away from the back of the handset.
- Place the handset on the base to charge.
- After 24 hours, plug the telephone line cord into the telephone wall socket.

2 Charge

General information

For information on safety instructions, cleaning, technical information or connecting to a switchboard, please refer to the 'General Information' section in the full user guide at bt.com/producthelp

Guarantee

Your BT3520 is guaranteed for a period of 12 months from the date of purchase.

Subject to the terms listed below, the guarantee will provide for the repair of, or at BT's or its agent's discretion the option to replace the BT3520, or any component thereof, (other than batteries), which is identified as faulty or below standard, or as a result of inferior workmanship or materials. Products over 28 days old from the date of purchase may be replaced with a refurbished or repaired product.

The conditions of this guarantee are:

- The guarantee shall only apply to defects that occur within the 12 month guarantee period.
- Proof of purchase is required.
- The equipment is returned to BT or its agent as instructed.

This guarantee does not cover any faults or defects caused by accidents, misuse, fair wear and tear, neglect, tampering with the equipment, or any attempt at adjustment or repair other than through approved agents.

This guarantee does not affect your statutory rights.

To find out what to do, if your phone is in or outside of the 12 month guarantee, please look in the full user guide at bt.com/producthelp

How to recycle your equipment

The symbol shown here and on the product means that the product is classed as electrical or electronic equipment, so DO NOT put it in your normal rubbish bin.

It's all part of the Waste Electrical and Electronic Equipment (WEEE) Directive to recycle products in the best way – to be kinder to the planet, get rid of dangerous things more safely and bury less rubbish in the ground.

You should contact your retailer or supplier for advice on how to dispose of this product in an environmentally friendly way.

Warning

You won't be able to call 999 from this phone if there's a power cut, so make sure you've got another way to call for help in an emergency.

R&TTE Directive & Declaration of Conformity

This product is intended for use within the UK for connection to the public telephone network and compatible switchboards.

This equipment complies with the essential requirements for the Radio Equipment and Telecommunications Terminal Equipment Directive (1999/5/EC).

For a copy of the Declaration of Conformity please refer to bt.com/producthelp



For a Better Future

We're always looking to make our products last longer and use less power, so we don't have such a big impact on the environment.

To find out about what we are doing, visit bt.com/betterfuture

Offices worldwide

The services described in this publication are subject to availability and may be modified from time to time. Services and equipment are supplied subject to British Telecommunications plc's respective standard conditions of contract. Nothing in this publication forms any part of a contract.

© British Telecommunications plc 2013.
Registered Office: 81 Newgate Street, London EC1A 7AJ.
Registered in England No. 1800000.

Designed and produced by The Art & Design Partnership Ltd.

Printed in China / Issue 2 / ADP10-13

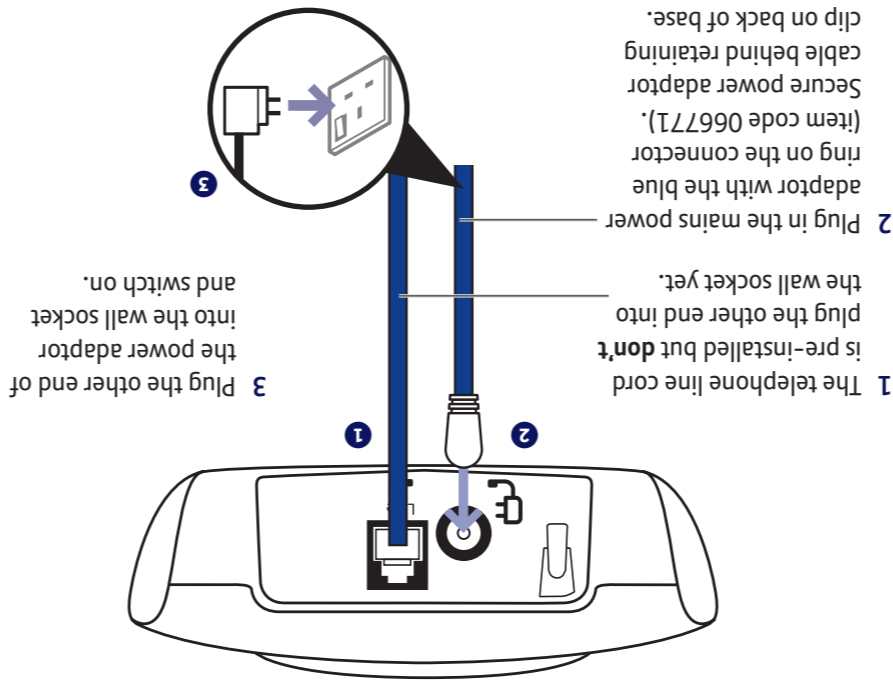

1 Plug in



User Guide

1 Plug in

2 Charge

3 Go!



BT3520

Digital Cordless Phone with Answering Machine

Setting up is easy. Just follow the simple steps in this guide.

If you'd like further help, or to view the full user guide, please visit our website bt.com/producthelp or call our helpdesk on 0800 218 2182*

* Calls made from within the UK mainland network are free. Mobile and International call costs may vary.

Important: Only use the mains power adaptor, cables and rechargeable batteries supplied in this box, or this product may not work. Any replacement rechargeable batteries must be of the same type. BT accepts no responsibility for damage caused to your BT3520 by using any other type of batteries.

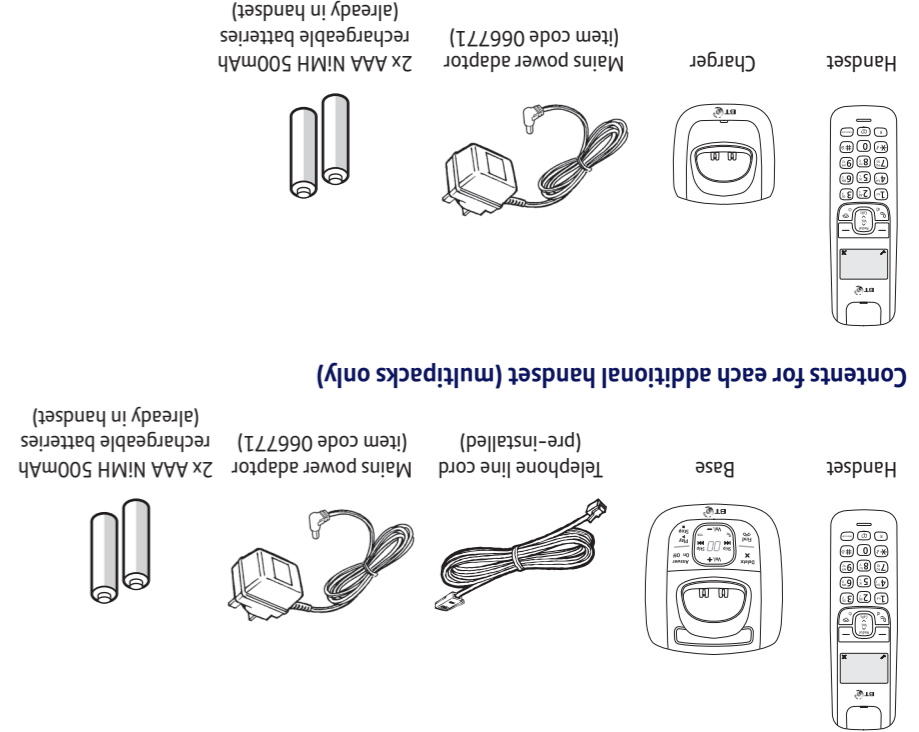

Check box contents

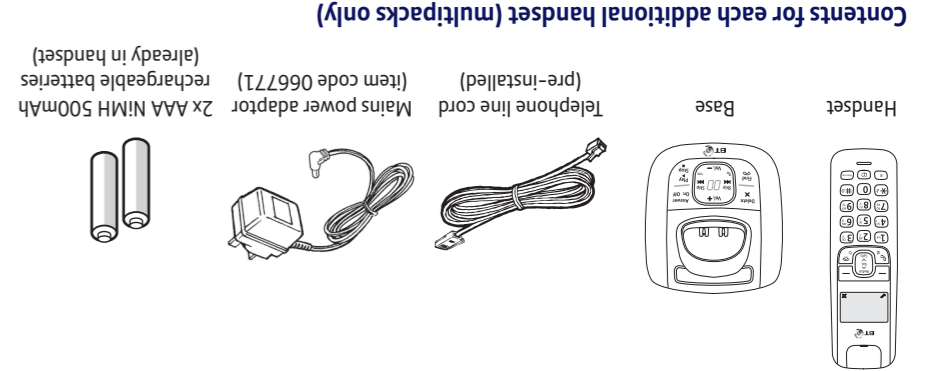

Your phone

Handset

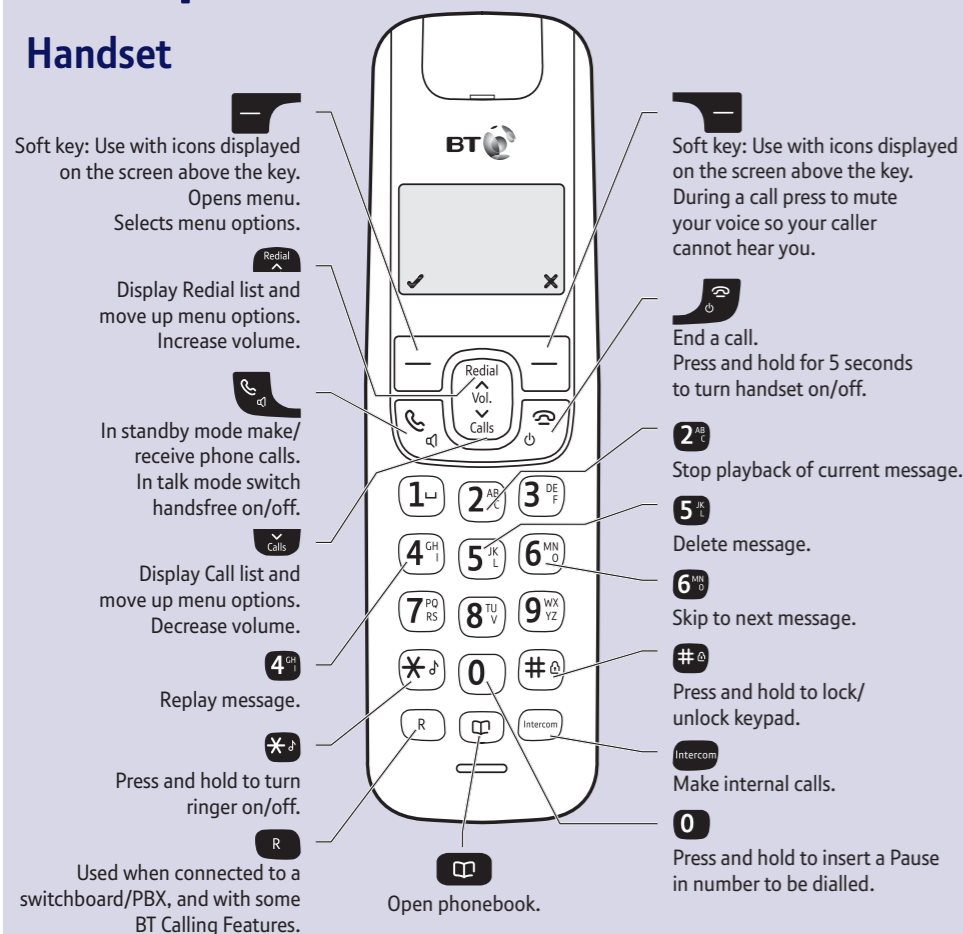

The answer machine handset controls on buttons **2**, **4**, **5** and **6** will only work when a message is being played on the handset.

Base

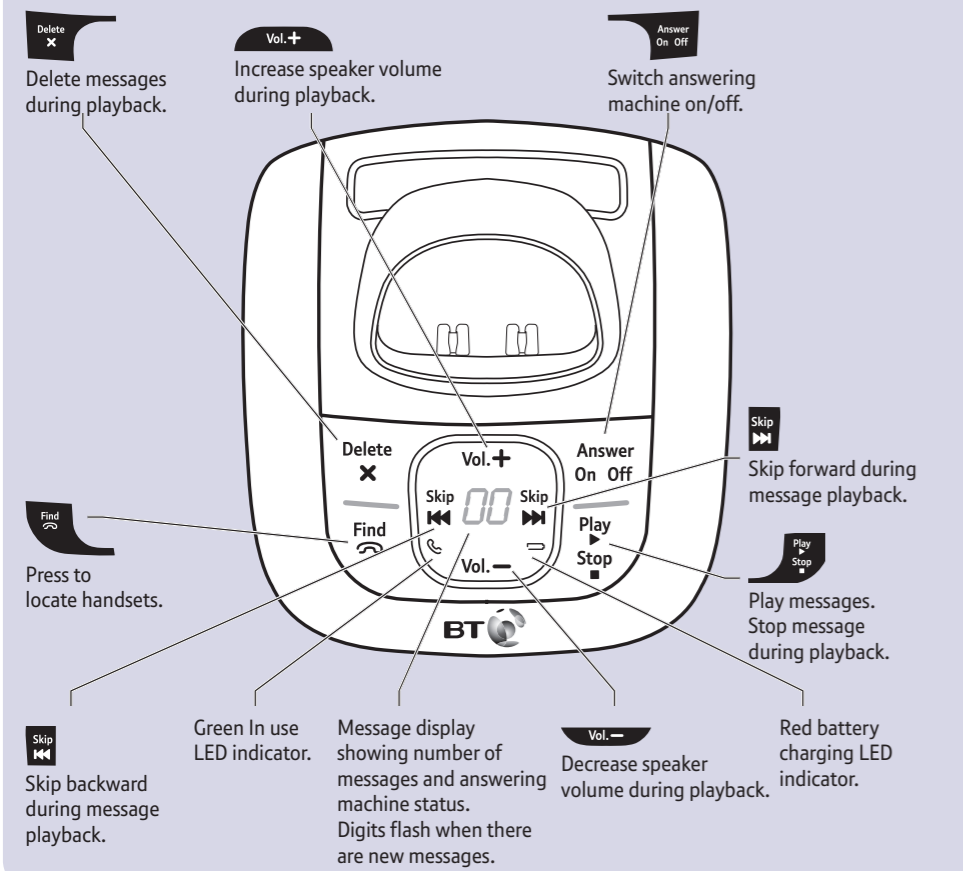

3 Go!

Set time and date

Press to open the main menu.

Press to scroll to HS SETTINGS and press soft key. DATE & TIME is displayed, press .

Press to SET TIME and press soft key. Enter 2 digits for the hour and 2 for the minute using the 24hr format and press soft key. You will hear a confirmation tone.

Press , SET DATE is displayed. Press . Enter the day, month and year using the dd-mm-yy format and press . You will hear a confirmation tone.

Making calls

Press then dial the phone number. Press to end the call.

Answering calls

If you have subscribed to Caller Display, the caller's details will be displayed before you answer (see below and also the full user guide online at bt.com/producthelp for details).

Lift the handset from the base or charger to answer incoming calls. If the handset is **not** on the base or charger, press .

Handsfree

Press during a call to switch between the earpiece and the loudspeaker.

Secrecy

Press the soft key during a call to activate secrecy mode, if you want to prevent the caller hearing anything from your end. Press the soft key again to resume your call.

Redial (up to last 10 numbers called)

Press to open the list of most recently dialled numbers. Press or to scroll through the list.

Press to redial the number displayed or press to access the options menu.

Phonebook

Storing new phonebook entries (up to 50)

Press to open the phonebook. The first entry (or EMPTY) is displayed.

Press the left soft key, ADD is displayed. press . NAME is displayed. Using the letters on the keypad, enter the name, then press . You may need to press the same button a few times until the letter you want is displayed. For example, press **2** once for A, or twice for B. NUMBER is displayed, enter the phone number for the entry and press . If you make a mistake, press to delete the last digit or letter entered.

Press or to select a ringtone you want to be played when this caller rings you and press to confirm. Press to return to standby.

Dialling a phonebook entry

Press . Scroll or to the entry you want. Press to dial.

Or, search alphabetically using the keypad to enter the first letter of the name you want then scroll or to the exact entry and press to dial.

Caller Display and the Call list

You must subscribe to a Caller Display service for this feature to work. Your network provider may charge you for this service.

View and dial from the Call list

Press , then or to scroll through the last 40 incoming calls.

The indicates new missed calls. The number of New Calls to the handset is shown on the standby screen until they have all been viewed in the calls list.

The icon is displayed when the phone number is too long to be fully shown on the screen. Press to allow you to scroll through the rest of the number.

Press to dial the number displayed.

Copy a Call list number to the phonebook

Press , then or to the entry you want and press .

Press until STORE NUMBER is displayed and then press . NAME is displayed.

Enter a name using the keypad and press . The number is displayed, press to confirm.

You will hear Melody 1 played, press or to choose a ringtone you want to be played when this caller rings you and then press .

Answering machine

Your answering machine is on and ready to record messages. The controls are shown in the base diagram to the bottom left and the features can also be accessed via the handset ANSWER MACHINE menu.

Recording your own outgoing message

Press . The display shows ANSWER MACHINE, press .

Press to scroll to ANSWER SETTINGS and press .

Press to scroll to OUTGOING MSG and press .

Press or to select either ANSWER & RECORD or ANSWER ONLY and press .

Press to scroll to RECORD MSG and press to record your message.

When prompted, speak your message into the handset. When finished press . Your message will be played back to you. Press if you want to delete the message.

Set the answer delay

To set the number of rings that are played before the answer machine picks up:

Press . The display shows ANSWER MACHINE, press .

Press to scroll to ANSWER SETTINGS and press .

Press to scroll to ANSWER DELAY and press .

Press or to select the number of rings before the answer machine answers: 2-9 rings or time saver and press .

For detailed instructions on all the answering machine features see the full user guide online at bt.com/producthelp

Help

Most problems can be fixed with a few simple checks.

Problem	Solution
No dial tone	Only use the cables and batteries supplied. Make sure both the mains power adaptor cable and telephone line cord are plugged into the correct sockets.
Poor speech quality	Make sure the product is not located too close to other electrical appliances. This can also help improve the handset range from the base.
Battery icon flashing and scrolling digits	The battery charge is very low. Make sure you charge the batteries for 24 hours before use to ensure maximum battery performance.
Using broadband on the same phone line?	Make sure you plug the phone into the wall socket via an ADSL microfilter (not supplied), otherwise you may have problems with this product and your broadband service. ADSL microfilter If you use BT Infinity, you will not need to use an ADSL microfilter. For other types of broadband, please check with your provider if a microfilter is required.
Answer machine not answering calls	Check the answer machine is on and set to Answer & Record. Also check that the ring delay is set to answer before any voicemail service (e.g. 1571) on the line.

Find out more

- Frequently Asked Questions are available at bt.com/producthelp
- If you'd like more detailed instructions, a full user guide is available to download from bt.com/producthelp
- If you cannot find the answer to your problem in the full online user guide, then please call our free Helpline on 0800 218 2182*. Our dedicated advisors are more likely to be able to help you than the retailer where you made your purchase.
- This document is also available in other formats, such as Large print, Braille and Audio CD. If you would like a copy, please call 0800 218 2182*.