

# SWITCHING OFF THE PSTN: MIGRATING FROM ANALOGUE TO DIGITAL LANDLINES

AUGUST 2023

# CONTENTS

Executive summary	4
<b>1 Introduction</b>	<b>8</b>
<b>2 The context for the migration to All-IP</b>	<b>9</b>
2.1 The migration to All-IP will change how voice calls are made	9
2.2 PSTN switch off is happening around the world	10
<b>3 PSTN switch off and migration to All-IP will offer a more resilient voice communication service in the UK</b>	<b>12</b>
3.1 Maintaining and repairing the PSTN is increasingly difficult	12
3.2 The PSTN equipment is increasingly subject to faults	13
<b>4 Benefits of migration to All-IP</b>	<b>16</b>
4.1 All-IP is much more reliable	16
4.2 Benefits to users of a more advanced digital All-IP network	17
4.2.1 Increased security	17
4.2.2 Innovation in connected products supporting telecare	18
4.2.3 Supporting digital inclusion	19
4.3 The environmental benefits of switching off the PSTN	20
4.3.1 Energy savings from decommissioned PSTN equipment	20
4.3.2 Power savings from decommissioned copper network infrastructure	21
4.4 All IP will support the take up of full fibre broadband	21
<b>5 BT Group has supported actions to mitigate the migration challenges</b>	<b>23</b>
5.1 Communications and outreach	23
5.2 Technical preparation for BT Group, other CPs and service providers	24
5.3 Industry cooperation and coordination	24
5.4 Mitigations for customers with specific demands for their PSTN service	25

6	Conclusions and recommendations	28
	<b>Annex A - Modelling assumptions</b>	<b>31</b>
	A.1 Welfare costs of outages	31
	<b>A1. Project number of outages.</b>	31
	<b>A2. Apply this to numbers of lines and future availability</b>	31
	<b>A3. Estimate numbers of residential voice, telecare (2m) and business users.</b>	31
	<b>A4. Estimate welfare impact of an outage.</b>	31
	A.2 Estimating productivity and labour participation impacts	32
	A.3 Number of PSTN lines	34
	<b>Annex B - Glossary</b>	<b>35</b>

## Executive summary

### The UK is upgrading its communications infrastructure

The UK is in the middle of a once in a lifetime upgrade to fixed communications technology and infrastructure. It will replace analogue copper-based networks rolled out in the 20<sup>th</sup> century, primarily to deliver voice products, with future-proof, digital, full fibre networks capable of supporting the connectivity needs of UK consumers, businesses and the broader economy for the next century. Research conducted for Openreach suggests that their full fibre network will boost the UK's annual economic output ("GVA") by £72bn as a result of productivity and workforce gains by 2030.<sup>1</sup>

In this context Frontier Economics was commissioned by BT Group to consider the benefits of migration to All-IP. In the process of writing this report, Frontier Economics gathered information from stakeholders<sup>2</sup> affected by the migration, and commercial end users.

### Landlines are going digital by 2025

As part of this upgrade, UK telecoms network operators (BT Group, Virgin Media and KCom) will retire the analogue equipment currently used to provide voice services over the legacy copper infrastructure, known the Public Switched Telephone Network (PSTN). Legacy services (such as Integrated Services Digital Network (ISDN) and Featureline) will also be retired as part of the move to digital landlines.

BT Group will continue to provide voice and broadband services throughout the UK, in line with its Universal Service Obligation, using new "All-IP" equipment to deliver voice services over broadband lines, including the new full fibre infrastructure. All established telecoms operators globally are upgrading their networks and phasing out legacy analogue technology, with a number of countries having already completed this migration.

While the roll out of full fibre networks will continue for the rest of the decade, there is a pressing need to rapidly migrate customers off the analogue PSTN technology and onto digital, due to the age of the underlying equipment. The current PSTN equipment in local telephone exchanges was installed in the 1980s and 1990s to meet the needs of consumers and businesses then, principally voice calls but also certain data services such as faxes, dial up internet and alarm systems. Parts of it are now almost 40 years old and a long way beyond its intended life span and spare parts are no longer manufactured.

The equipment to date has consistently demonstrated its resilience by reusing components and benefiting from the expertise of experienced engineers. However, as technology advances, spare parts for the PSTN become increasingly difficult to source and PSTN engineers leave the workforce,

---

<sup>1</sup> Research conducted by CEBR for Openreach, taken from 'Openreach hits 10 million full fibre milestone', 22 March 2023 GVA is the measure of the value of goods and services produced in the economy. <https://www.openreach.com/news/openreach-hits-10-million-full-fibre-milestone/>

<sup>2</sup> These included BT Consumer, BT Business, BT Networks, Openreach, Virgin Media O2, Tech UK, UK national government departments and local government.

we have the opportunity to upgrade performance further and minimise the chances of any potential widespread failure.

Back in 2017 BT Group announced that all users of PSTN services (including ISDN and Featureline) would be migrated to new All-IP services by 2025, giving industry eight years to prepare for the migration. This is in line with other UK network operators, such as Virgin Media and KCom. Across all Communications Providers (CPs), the programme will migrate up to around 19.5m<sup>3</sup> lines using PSTN technology to either the All-IP voice platform or to other IP based technologies.<sup>4</sup>

### Delaying PSTN switch off will have a significant impact on users and the wider economy

BT Group's target to complete migration from PSTN by 2025 was based on an assessment of when the maintenance of the PSTN would become unsustainable. This provided eight years to migrate all users. Since 2017, more than six million customers have migrated from PSTN to new All-IP services with around two million consumer customers moving to BT's Digital Voice service. The vast majority of users will have a straightforward migration to the All-IP voice platform.

However, for some customers, such as vulnerable users, the migration may be more complex. In March 2022 BT Group initiated a temporary pause of the migration of its Digital Voice services for those consumer customers that did not want to move, in order to provide more time to mitigate some of the challenges involved in these cases. These mitigations will be in place by the time BT Group restarts the migration process during 2023, which will be critical to meeting the 2025 deadline. Despite the temporary pause of Digital Voice for consumer customers, business customers have continued to migrate from analogue to digital throughout.

Ensuring a timely switch off of PSTN brings numerous benefits to users of communications networks, and to the UK more widely. These include the following:

- **All-IP offers greater reliability.** Recent evidence shows that the rate of faults on the PSTN is increasing rapidly. It is likely that if the switch off were to be delayed the rate of faults would increase such that by 2027 approximately 1.4m lines could be affected over a year (an increase of 283% in the rate of faults compared to 2021). Transitioning from the old network presents an opportunity to reduce the risk of faults and ensures customers will continue to receive uninterrupted service at times of need. The welfare cost to UK consumers who are unable to use their fixed line phone could reach **£22m cumulatively by 2027.**
- **There are benefits and innovations** offered by All-IP networks. All-IP will enable a new generation of digital devices with vastly improved functionality. There are many examples of innovation. For example, an All-IP network would enable the 2 million telecare users to upgrade to the next generation of telecare digital devices.<sup>5</sup> An All-IP network also offers greater security from fraud than an analogue network as scam calls can be much more effectively identified and

---

<sup>3</sup> See Table 1.

<sup>4</sup> For customers that are currently using the PSTN for data services.

<sup>5</sup> TSA, 2017, [A digital future for technology enabled care?](#)

screened out. If technological upgrade led to even a modest 25% reduction<sup>6</sup> in financial fraud, avoiding a two-year delay would save users of up to **£1.7bn cumulatively** in direct financial losses and cost associated with fraud.

- **Environmental benefits, as All-IP networks are much more energy efficient** and hence migration from PSTN will help the UK meet its net zero objectives by reducing demand for electricity (section 4.3).
- In addition, **the UK can achieve *indirect* benefits associated with investments in the ongoing programme to upgrade the UK's communications infrastructure to full fibre.** This is because migration to All-IP voice is a step towards the migration to a full fibre network; and migrating customers off the PSTN presents network providers with an opportunity to engage with their customers to prompt an upgrade to full fibre broadband where this is available. Given that the upgrade to full fibre networks is expected to unlock productivity benefits, even a relatively short delay in the migrations to a full fibre network would result in significant costs to the UK economy. If a delay in migration to All-IP led to a two year delay in take up of full fibre, based on research commissioned for Openreach<sup>7</sup> this implies that the UK economy would fail to see up to **£2bn** in foregone productivity savings and lost labour participation resulting in lower economic output during the period 2023 to 2030.

### Recommendations to support a successful migration

Migrating 19.5 million lines to a new network is a big challenge, made more difficult by the wide range of stakeholders involved, including other CPs, businesses, local and national government, and consumers, as well as the network operators themselves. As noted above, while the majority of migrations will be relatively simple, a small proportion will be more complex. For example some vulnerable customers use their voice line to provide telecare services. Some business customers such as Critical National Infrastructure operators (CNI) have specialised needs and edge use cases (such as remote telemetry devices etc) but smaller SME/SOHO (Small Medium Enterprises / Small Office Home Office) may not have dedicated IT support to support the transition.

While BT Group and the wider industry have put in place a wide range of initiatives to ensure the migration is a success, including availability of technical solutions for each and every customer, there is a role for government to address potential coordination failures as the deadline approaches. Therefore, this report makes the following recommendations.

### Government has a role to play to ensure the migration is a success

The migration should be supported by a simple, clear and consistent communication message adopted by all stakeholders, where government and Ofcom use their considerable communications capacities to help build understanding and trust with the wider public.

---

<sup>6</sup> One UK telecoms operator found that following the voluntary introduction of their Calling Line Identification, they had seen a 65% reduction in complaints regarding scam calls. See <https://www.wired.gov.net/wg/news.nsf/articles/ofcom+plans+crackdown+on+fake+number+fraud+23022022131000?open>.

<sup>7</sup> This is based on analysis produced by CEBR. See <https://www.openreach.com/fibre-broadband/full-fibre-impact>. There is an updated report due to be published in H1 2023. See <https://www.openreach.com/news/openreach-hits-10-million-full-fibre-milestone>

Some CPs may have less incentive to communicate with their customers about the migration particularly if they have invested in legacy equipment or have long term contracts for PSTN services with customers. Ofcom can play a positive role in ensuring that all CPs (including CPs that have the retail customer relationships, but do not have PSTN equipment) contribute to the effort in actively preparing and migrating their customers.

### **A staged approach to migration**

A staged regional switch off could help the migration of consumers and local businesses. This would enable resources to be targeted in each area and learnings to be undertaken from each stage. It would provide all stakeholders with the visibility of the planned, staged migration so they can target resources in specific geographic areas. Whilst some UK business customers may wish to engage and migrate nationally, this regional approach has been successfully followed in many countries such as New Zealand, Germany, Switzerland and France.<sup>8</sup>

### **Telecare services providers should be able to efficiently access CP testing facilities to ensure their telecare devices are compatible with All-IP**

There are many millions of devices that currently use PSTN lines to provide basic data communication, whether telecare devices, alarms, or monitoring devices. Service suppliers who use these devices and supply them to end users will have to ensure they are compatible with All-IP services and if not compatible, they need to be swapped out. In order to ensure that the devices are compatible they can be tested at dedicated labs that have been set up by CPs.

CPs should ensure that there are no barriers to using the testing facilities. As the 2025 PSTN switch off approaches it will become ever more important that device manufacturers are able to use and access the testing labs.

All service providers should be strongly encouraged to test analogue devices or source new digital devices well in advance of the 2025 deadline. However, many service providers are only just starting the procurement process for replacement devices and some service providers have expressed concerns that there may not be enough of certain digital products to replace all the analogue ones.

### **Migrating customers with more complex requirements should be carefully planned**

To ensure that their migration is smooth and without interruption a number of actions could be taken to support residential users with more complex requirements and business users with edge use cases. The protocol and standards for facilitating the migration in individuals' homes should include specific plans for vulnerable users to ensure that migration does not occur where a vulnerable user's device is not compatible with All-IP. For business customers with edge use cases, telecoms network operators should ensure that technical solutions are available to provide connectivity to those customers ahead of the 2025 deadline.

---

<sup>8</sup> Plum, 2018, Preparing the UK for an All-IP future: experiences from other countries, page 7.

# 1 Introduction

In the coming years the UK telecoms network operators (BT Group,<sup>9</sup> KCom<sup>10</sup> and Virgin Media<sup>11</sup> O2) will retire their legacy analogue “Public Switched Telephone Network” (PSTN) equipment that provides voice communications in the UK. Legacy services (such as Integrated Services Digital Network (ISDN) and Featureline) will also be retired as part of the move to digital landlines. The process will see them migrate customers to new “All-IP”<sup>12</sup> based services including voice and other business services. This upgrade will ensure that the UK’s voice communications network remains reliable and resilient in the coming decades.

Migrating all UK customers using legacy technology is undoubtedly a logistical challenge for all involved stakeholders. It involves many different stakeholders including: phone network providers (NPs); the retail Communication Providers (CPs) that own the direct customer relationships; or service providers that provide devices and services which currently rely on the analogue PSTN. Given the challenges in migrating certain users (whether vulnerable users or business users with complex needs) some have argued in favour of delaying the migration. However, delaying the migration will increase risks to the UK voice communications network.

In this context Frontier Economics was commissioned by BT Group to consider the benefits of migrating to All-IP. In the process of writing this report, Frontier Economics gathered information from stakeholders<sup>13</sup> affected by the migration, and commercial end users.

The remainder of this report is structured as follows:

- section 2 summarises the technological context for the migration to All-IP;
- section 3 explains why the migration to All-IP is necessary under the declared time frame and explains the constraints that CPs are facing in reliably maintaining the PSTN;
- section 4 outlines the implications which could result from a delay to switch off of the PSTN and migration to All-IP;
- section 5 explains the challenges to migration and provides an overview of the current activities to mitigate these issues; and,
- section 6 concludes and makes observations for stakeholders on how a successful migration can be enabled.

<sup>9</sup> <https://business.bt.com/why-choose-bt/insights/digital-transformation/uk-pstn-switch-off/>

<sup>10</sup> KCOM, 2021, [Regulatory Financial Statements](#).

<sup>11</sup> Ofcom, 2022, [Telecommunications Market Data Update](#).

<sup>12</sup> This report uses the term “All-IP” to describe the services that will replace PSTN. There are many products offered over the PSTN. A voice line is by far the highest volume service. BT Group offers its residential customers an IP voice service called “Digital Voice”. Though there are other PSTN based services such as ISDN. CPs also offers a suite of managed services to businesses that rely on the PSTN such as Premise PBX, Premise Contact Centre, Audio Conferencing, Telepresence and dedicated video rooms.

<sup>13</sup> These included BT Consumer, BT Business, BT Networks, Openreach, Virgin Media O2, Tech UK, UK national government departments and local government.



## 2 The context for the migration to All-IP

### 2.1 The migration to All-IP will change how voice calls are made

While the volume of voice traffic carried over the PSTN has declined over the last decade, as users increasingly use mobile services or “App” solutions over broadband to make calls (such as Microsoft Teams or WhatsApp), customers still make 40 billion minutes of fixed voice calls in the UK each year.<sup>14</sup>

For most customers, their voice traffic is routed through dedicated “PSTN” equipment housed in local telephone exchanges. The PSTN also carries basic data traffic (i.e. “narrowband” data services)<sup>15</sup> that can support limited functionality data such as alarms.<sup>16</sup> Much of the PSTN equipment is from the 1980s and has long since reached its expected end of life. Network providers such as BT Group, KCom and Virgin Media O2 plan to retire the PSTN equipment. BT Group plans to switch off their PSTN in 2025.<sup>17</sup> The migration to All-IP will mean that users will receive their voice services (and other data services) via their router.<sup>18</sup>

This migration is taking place at the same time as the UK digital network builders are upgrading networks to full fibre<sup>19</sup> which will enable Gigabit capable data services. The migration to All-IP technology does not imply that users have to upgrade to full fibre, since All-IP can also be provided over existing copper based broadband connections. However, All-IP is a pre-requisite for migration to full fibre services, and migration to All-IP can support migration to full fibre, as the PSTN will not work over full fibre (see Figure 1).

<sup>14</sup> Ofcom, 2022, Communications market report, <https://www.ofcom.org.uk/research-and-data/multi-sector-research/cmr/the-communications-market-2022/communications-market-report-2022-interactive-data>.

<sup>15</sup> For example faxes or alarms.

<sup>16</sup> The USO requires BT Group to offer a basic internet access service (i.e, limited slow data service) but this has since been superseded by the broadband USO. In September 2022 Ofcom in consultation with the Department for Culture Media and Sport (now Department for Science, Innovation and Technology) withdrew the requirement for BT Group and KCom to offer a service capable of delivering fax communications. The Universal Service Order specifying the BT Group and KCom’s universal service obligations requires the operators to offer “*data communications, at data rates that are sufficient to permit functional Internet access, taking into account prevailing technologies used by the majority of subscribers and technological feasibility*”, 155 See paragraph 1 of Schedule 1 to the Universal Service Order <https://www.legislation.gov.uk/ukxi/2003/1904/schedule/made>.

<sup>17</sup> There are a number of intermediate steps on the way to this milestone Following BT Group’s 2017 announcement that it would close PSTN in 2025 it launched a consultation on the withdrawal of its PSTN related products. In 2018-19 it notified the intended withdrawal of legacy products and brought new IP-based products to market. In 2023 it will stop selling certain PSTN products to new customers with PSTN being withdrawn on 31 December 2025.

<sup>18</sup> Users that currently do not have a router will have one provided to them by their CP.

<sup>19</sup> Virgin Media is also upgrading its Hybrid Fibre Coaxial cable network.

**Figure 1 Migration of voice to All-IP is a pre-cursor to migration to full fibre**

There are two distinct technology upgrades which must be sequenced. Currently most customers receive voice using full copper and PSTN (1). BT Group is upgrading its voice service from PSTN to All-IP using part copper part fibre (2). Alongside this BT Group is upgrading its network infrastructure from copper to fibre. Customers need to have migrated to All-IP voice for BT Group to migrate their line to full fibre (3).

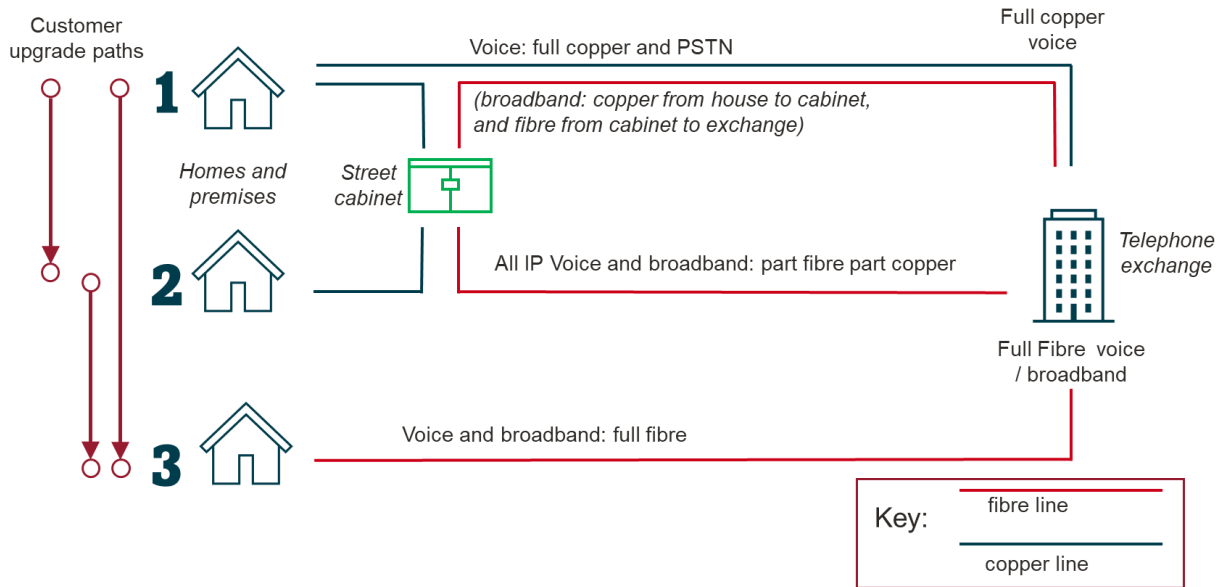

Source: Frontier Economics

## 2.2 PSTN switch off is happening around the world

The development of the telecommunications markets in other countries has followed a similar path to the UK (Figure 2). All developed countries are in the process of replacing their PSTN. The speed of this transition depends on a number of factors including the degree to which full fibre networks have been rolled out, the ability to maintain the legacy PSTNs, and support from Government and local regulators.

Estonia and the Netherlands have already switched off their PSTN, while Germany, Norway and Sweden are also ahead of the UK in making the switch. By 2020, Germany had managed to switch 99% of users, which equates to 25m households, to All-IP after announcing plans to migrate to IP services in 2014. Norway announced in 2019 it would switch off its copper network by the end of 2022. In under three years it has transferred the majority of its customers off its legacy voice network, with under 12,000 telephony lines remaining across the residential and business market.

Figure 2 PSTN switch off across Europe

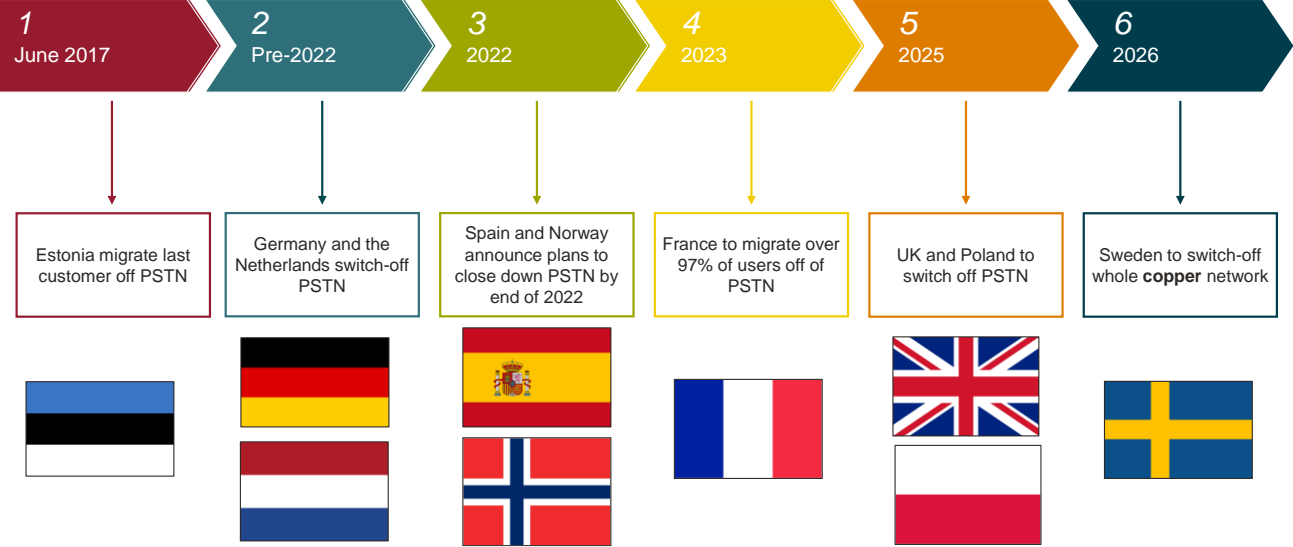

Source: WIK Consult 2022, [Copper switch off whitepaper](#)

### 3 PSTN switch off and migration to All-IP will offer a more resilient voice communication service in the UK

The PSTN can no longer be relied on to provide a sufficiently resilient service. This section summarises the increasing difficulty of maintaining and repairing the PSTN (section 3.1) and describes why the risk of failure of the equipment is growing (section 3.2).

#### 3.1 Maintaining and repairing the PSTN is increasingly difficult

The last generation of the PSTN technology was installed in a context where the main service was voice telephony. The expectation when equipment was installed in the 1980s and 1990s was that it would begin to be replaced around ten years after installation.<sup>20</sup> However, as the PSTN equipment continues to be used well beyond its intended asset life it becomes much harder to maintain and repair, and hence the incidence of faults is increasing rapidly.

##### **Legacy network equipment is increasingly difficult to repair and maintain**

*Spare parts for legacy and obsolete equipment are scarce*

Manufacturers have stopped producing the parts necessary for repairs making it increasingly challenging to come by the spares. It is now no longer profitable to produce parts for legacy equipment initially installed over 40 years ago.

Any repairs to the network therefore now involve recycling parts currently in use by “shrinking” the network, i.e. concentrating PSTN equipment in fewer locations and cannibalising decommissioned equipment. This strategy suffers from diminishing returns as it is becoming harder to find parts of the network that can be decommissioned in order to source parts. Furthermore, aging components which are working when in situ, may fail when removed and reinstalled elsewhere.

Over time spares will become increasingly scarce, leaving the network vulnerable to significant outages. The overall lack of spares means engineers have to travel longer distances to locate working spares to repair fault incidents, which will increase the time to resolve outages.

*There are limited and dwindling engineering skills to repair and maintain PSTNs*

The PSTN is a legacy network and hence knowledge of it is mostly concentrated within the more experienced workers. As engineers retire there is dwindling knowledge of PSTN across the industry, leading to a lack of labour to service it. While training a new generation of workers to operate and repair the legacy and obsolete technology is an option in theory, such a training programme would

---

<sup>20</sup> BT Group initially planned to migrate voice users to All-IP in 2005. However, in 2008 BT Group decided to extend the life of the PSTN in part reflect that fact that BT Group considered that the PSTN could continue to provide resilient voice services for a number of years: being based on digital technologies, the last generation of PSTN equipment proved to be relatively robust compared to previous generations; and even if the original equipment manufacturers were no longer manufacturing or supporting the equipment, BT Group was able to support the PSTN through a combination of internal resources and external support.

crowd out the availability of engineers with skills to operate, install and repair new digital networks, at a time when the industry is facing a shortage of qualified staff.<sup>21</sup>

The limited remaining engineering knowledge is geographically dispersed over the UK. Where faults occur on the network it therefore inevitably means that engineers with specialist knowledge have to travel further which can add to the cost and time taken to repair the network.

### 3.2 The PSTN equipment is increasingly subject to faults

These issues mean that the PSTN can no longer continue to offer a reliable and resilient service. The mitigations put in place to extend its life have reached their limits. As 2025 is approached there is an ever-increasing rate of failure of the PSTN.

#### **End of life equipment will tend to fault more frequently**

The age of the PSTN equipment means the rate of failures has begun to increase rapidly. By June 2022 there had been 1,727 incidents (an incident is defined as a fault affecting over 500 lines) in the first 6 months of the 2022/23 financial year. This level already exceeded the total for the whole of 2021/22; and was 143% higher than the same period the previous year.<sup>22</sup> The risk of failure in the future is also high and BT Group has seen individual exchanges/concentrators increasingly having prolonged outages. It is likely that if the switch off were to be delayed the rate of faults would increase such that by 2027 approximately 1,400,000 lines could be affected over a year (an increase of 283% in the rate of faults compared to 2021).

The number of lines affected by a fault will depend on the equipment affected (Figure 3). A fault on a “line card” could affect 12 lines; a concentrator fault could affect 2,000 lines; and a processor fault could affect up to 50,000 lines.

---

<sup>21</sup> External suppliers are currently used by BT Group to augment its engineer capacity to maintain and repair the network. Similar to BT Group’s in-house engineers, many of these engineers have worked on the PSTN for a number of years and have specialist knowledge of how it operates. However, these external suppliers are suffering from the same issues as BT Group, as many of the experienced engineers have started to retire.

<sup>22</sup> Data provided by BT Group.

**Figure 3 Customers affected by PSTN faults**

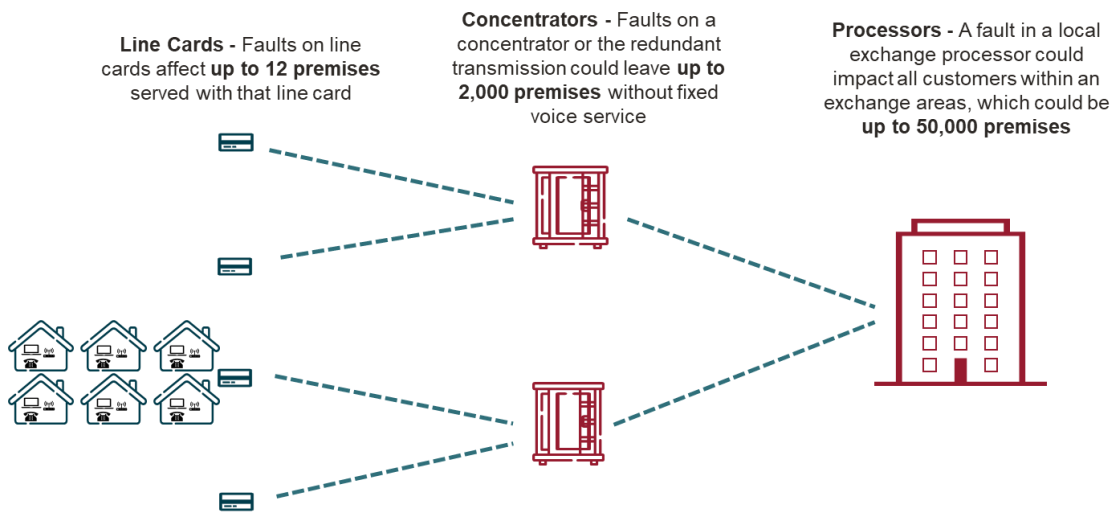

Source: Frontier Economics

**PSTN technology is increasingly subject to heat related faults**

All electronic equipment is designed to operate within a specified temperature range. When temperatures in the location where the equipment is located fall outside this range then the equipment is more likely to fault. While modern equipment is more tolerant to a wider range of temperatures, PSTN equipment has a narrower operating temperature range and will be more likely to be affected by temperature.

According to BT Group a temperature of change greater than 4°C, in short span of time, causes a sharp increase in PSTN faults. Summer and winter are therefore especially challenging for the network and see a higher number of incidents,<sup>23</sup> with this risk likely to grow in the future as climate change brings more and longer lasting heat waves.

The impact of temperature on faults can be observed in Figure 4 which shows how the number of lines where PSTN is available (blue line) is closely related to the number of rooms<sup>24</sup> where PSTN equipment is stored with a temperature over 35°C (red line). Periodic increases in temperature lead to a spike in faults. While the percentage of lines with a fault at any point in time is low, the number of customers affected and the time they have no access to voice telephony is significant. For example, in the week of the record high temperatures in July 2022, incident volumes rose by 199% from 75 to

<sup>23</sup> In the summer of 2020 BT Networks invested £102m into cooling equipment in an attempt to reduce the frequency of failures. However, this investment was not sufficient to keep PSTN system rooms cool enough during subsequent heatwaves, taking into account the age of the equipment with failures increasing in 2022. It would require an increasing level of investment to further cool the system rooms which is inefficient in the context of end of life equipment.

<sup>24</sup> PSTN equipment is housed in dedicated rooms, cabinets and buildings. While some of these may have environmental control smaller cabinets are ventilated manually which can be more prone to over heating or excessively cold temperatures.

224 incidents per week, reducing availability for approximately 150,000 lines.<sup>25</sup> Sudden drops in temperature during winter also cause sharp falls in availability. For example, when outdoor temperatures fell by 7°C in the week of 7 January 2022, faults caused over 1.3 million lost call hours.

**Figure 4 PSTN reliability performance July 2019 – August 2022**

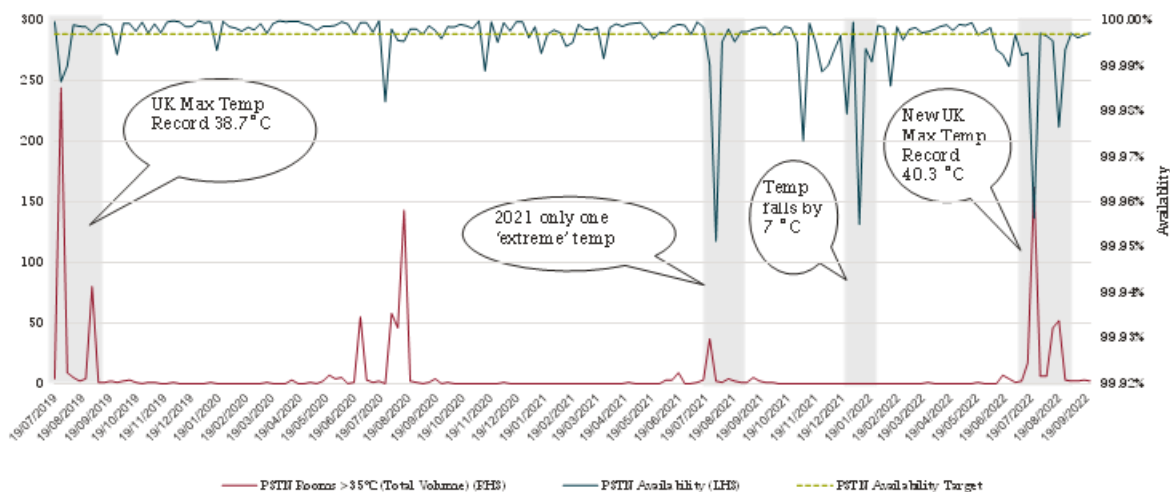

Source: BT Networks

**Migration to All-IP will act as a stepping stone to more reliable full fibre networks**

Migration to All-IP is a pre-cursor to take up of full fibre since customers will have had to have migrated to All-IP voice before or at the point of taking up full fibre. The copper access network exhibits a relatively high level of faults<sup>26</sup>. Full fibre is much less likely to fault and is more resistant to rain and flooding, this will mean future full fibre networks coupled with All-IP will be much more resilient and reliable.

<sup>25</sup> This is assuming that each incident affects 670 lines.

<sup>26</sup> One 2013 study for Openreach suggested approximately 2 lines per 1000 each week experienced a fault, or around one in ten copper lines had a fault in each year. "Total average fault rates for MPF, WLR+SMPF and WLR/PSTN have remained at broadly the same level over the same time period (Figure 4), i.e. close to 2.3 weekly faults per thousand lines for WLR+SMPF, 2.0 for MPF and a lower level of 1.6 for WLR/PSTN." [https://www.ofcom.org.uk/data/assets/pdf\\_file/0020/80912/openreach\\_-\\_deloitte\\_report.pdf](https://www.ofcom.org.uk/data/assets/pdf_file/0020/80912/openreach_-_deloitte_report.pdf)

## 4 Benefits of migration to All-IP

Delay in migration to All-IP risks missing out on potential benefits associated with the technology upgrade. There are different sources of benefits of All-IP. These relate to:

- the increased reliability of All-IP (section 4.1);
- the benefits and innovations offered by All-IP networks (section 4.2);
- the environmental benefits as All-IP networks are much more energy efficient and hence help the UK meet its net zero objectives by reducing demand for electricity (section 4.3); and,
- furthermore, the benefits of investments in the ongoing programme to upgrade the UK's communications infrastructure to full fibre (section 4.4).

### 4.1 All-IP is much more reliable

The increasing number of faults on the PSTN adversely affects users.<sup>27</sup> A loss of service will affect different users in different ways.

First, the vast majority of users rely on the PSTN for voice calls only. During PSTN outages, customers are unable to make calls over the fixed network. This cost is likely to be particularly keenly felt by those users who rely on their voice service for communications. These may include older or vulnerable users who do not have a mobile, or users in areas with poor mobile reception. The welfare cost to this group as a result of loss of service could reach £11.7m,<sup>28</sup> cumulatively to 2027, across the whole of the UK.

The second group affected are those customers who are particularly sensitive to faults as they rely on their voice line to support their health care. Vulnerable groups with telecare devices might lose protection offered by their devices until a fault is repaired. For these groups, who rely on their connected equipment to support their social care, a loss of service represents an increased risk to their health and wellbeing. The cost of mitigating this loss is high (for example by increasing in-person visits to vulnerable users that rely on pendant alarms). Though smaller in number, it is likely that their welfare loss as a result of a fault is high. The welfare cost to vulnerable users as a result of loss of service above the target level could be up to £2.5m<sup>29</sup> p/a across the whole of the UK (assumed to be £5m for a two year delay).

The third group are businesses and public sector organisations that rely on PSTN services. Businesses may be unable to complete sales if PSTN services fail. Others might have impaired service (loss of alarms, lifts or other functioning). Whereas faults might mean that Critical National

<sup>27</sup> In addition to the risk or fault associated with PSTN technology, users are exposed to faults associated with copper networks. Migrating customers across to more robust networks will avoid the costs associated with leaving them on rapidly deteriorating networks. All-IP in the long-run will run fully on fibre. Fibre is much less likely to fault than copper networks and is more resistant to rain and flooding, this makes fibre networks much more resilient and reliable.

<sup>28</sup> See Annex A.

<sup>29</sup> See Annex A.



Infrastructure (CNI) providers are unable to provide critical services including risk to life services. Falling reliability of the PSTN thus poses potential risks to the functions of this infrastructure, which could have wider consequences across the whole of the UK. The cost to business and public sector users as a result of loss of service above the target level could be up to £4.9m<sup>30</sup>, cumulatively to 2027, across the whole of the UK.

These faults will create real costs for users.<sup>31</sup> The total welfare cost of faults to UK customers caused by outages above the target level could reach £22m cumulatively up to switch off in 2027, following a two year delay, based on reasonable assumptions. Though the welfare cost of faults might in practice be even higher than these more direct costs of outages, since this estimate would exclude the psychological impact associated with the fear that a service they rely and depend on may not be available when they need it.

### 4.2 Benefits to users of a more advanced digital All-IP network

Migrating to All-IP will provide direct benefits to consumers, businesses and government which would be foregone if migration was delayed. The PSTN's decades old technology imposes limitations on the development of new products. In contrast, All-IP is based on advanced digital technology which means as well as providing high-definition quality sound on voice calls it will enable new capabilities and products which benefit and protect consumers.

#### 4.2.1 Increased security

All-IP services can use Artificial Intelligence (AI) technology to help reduce the incidence of scam calling. On a digital network, AI technology can be used to detect calling patterns and non-UK numbers which are disguised as UK based numbers. These calls are subsequently blocked helping to reduce the frequency of scam calls. As a result scammers are less able to contact their potential victims. Such an approach is not possible with analogue PSTN equipment.

#### All-IP will help reduce the cost of scam calls

Consumer fraud is enabled through many different channels such as websites, social media and texts. However, over half of all scams start with a phone call<sup>32</sup> as this enables the scammer to engage and build trust with the victim.

In 2021 unauthorised financial fraud losses across payment cards, remote banking and cheques totalled £1.3bn.<sup>33</sup> Scams also cause emotional and psychological harm on victims with many losing trust and confidence. A study by the consumer group Which? estimated this loss as £9.3bn a year or £2,509 per victim (significantly exceeding the direct loss per victim). According to Which? "The impact

---

<sup>30</sup> See Annex A.

<sup>31</sup> Changes in utility are also dependent on the degree of substitutability, for example outgoing fixed-line calls can be replaced by mobile phone calls but incoming calls are harder to replace. Similarly it is not possible to replace some services such as telecare services. Finally, values will differ across customer groups, with losses likely to be larger for certain vulnerable residential users and businesses. For example, many parts of the critical national infrastructure (CNI) in the UK rely on the PSTN for resilience.

<sup>32</sup> <https://www.nidirect.gov.uk/articles/phone-scams-and-cold-calls>.

<sup>33</sup> UK Finance, 2022, [Annual Fraud Report](#).

on wellbeing is substantially more than the average amount lost to fraud, estimated to be around £600 per victim."<sup>34</sup>

The switch to All-IP would allow CPs to use new technologies and techniques to prevent scam callers. These methods of dealing with nuisance callers can be separated into two categories;

- They can provide consumers with information about the call they are receiving so that they can make an informed choice as to whether to answer or return the call. CPs must provide these Calling Line Identification (CLI) facilities by default.
- They can also facilitate the blocking of calls at the consumer level. BT's Call Protect allows users to divert nuisance or fraudulent calls to their 'junk' voicemail.<sup>35</sup>

Mobile networks already offer versions of call blocking making them more secure, with Vodafone blocking around 675,000 calls every day. The calls are from known scammers who send high volumes of calls and texts to customers.<sup>36</sup>

All-IP will not eliminate phone related scams but will be able to reduce their impact. Assuming a pessimistic scenario that CPs will be able to implement a system that contributes to a 25% reduction in the incidence of scam calls<sup>37</sup> this would save consumers **£165m**<sup>38</sup> p/a in direct financial impacts and **£685m**<sup>39</sup> p/a in lost welfare as a result of the emotional distress. Compared with a 2027 switch off date, completing the migration by 2025 will deliver savings of **£850m** per year or **£1.7bn** cumulatively over the two year period.

### 4.2.2 Innovation in connected products supporting telecare

Telecare is a monitoring service that offers remote support to over 2 million<sup>40</sup> elderly, disabled and vulnerable people who live alone in their own homes.<sup>41</sup> It makes an increasingly essential contribution to health and social care and currently is estimated to be worth £630m per year,<sup>42</sup> although the value

---

<sup>34</sup> Which?, 2021, [Cost of scams](#).

<sup>35</sup> BT Group 2019, [Promoting trust in telephone numbers](#).

<sup>36</sup> <https://www.vodafone.co.uk/newscentre/smart-living/lifestyle/how-vodafone-protects-its-customers-from-scam-calls-and-texts/>.

<sup>37</sup> One UK telecoms operator found that following the voluntary introduction of their Calling Line Identification, they had seen a 65% reduction in complaints regarding scam calls. This implies a 25% reduction in the incidents of cool scams following the introduction of all IP voice is a reasonable assumption. See <https://www.wired.gov.net/wg/news.nsf/articles/ofcom+plans+crackdown+on+fake+number+fraud+23022022131000?open>.

<sup>38</sup> Calculated as the total cost of scams (£1.3bn) \* percentage of scams which originate from calls (50%) \* percentage of cam calls blocked by All-IP technology (25%).

<sup>39</sup> Calculated as the financial loss of scams (£164.2m) \* the ratio of financial to emotional loss found in the Which? report (2500/600 = 4.2).

<sup>40</sup> Source: DHSC in discussion with Frontier Economics.

<sup>41</sup> <https://www.telecarechoice.co.uk/what-is-telecare/>.

<sup>42</sup> Revenue of telecare providers. See <https://www.ibisworld.com/united-kingdom/market-size/telehealth-services>.

of these services is much higher to users. Many existing telecare devices rely on PSTN to function hence All-IP migration will have a large impact on the sector.

Going forward All-IP will allow for the development of many new telecare products for consumers and businesses.

### All-IP will support the take up and use of a new generation of telecare devices

Telehealth provides benefits to end users by enabling them to lead more independent lives which accommodate their health conditions. They offer more efficient ways of monitoring and treating users with certain conditions. Telehealth has been estimated to save the NHS £7.5bn annually.<sup>43</sup> This can be achieved through a reduction in GP, pharmacy and hospital visits in addition to shortening the length of these visits.

A recent White Paper by the Technology Enabled Care Services Association (TSA) stated that the *“forced move from analogue to digital telecare systems can be more than a replacement but an opportunity to improve telecare systems.”*<sup>44</sup> Examples of telecare opportunities could be:

- Data driven care which will allow health providers to predict risk and be proactive with responses, for example AI is as good as human experts at recognising skin cancers.
- Voice interaction systems can encourage people to take exercise, suggesting appropriate activities depending on the weather and the options available locally.
- UK councils will be able use GPS tracking systems to monitor people with dementia.
- Existing analogue devices have a failure rate as high as 20%. New digital devices have a much higher connectivity reliability, in addition to this status being visible to users.<sup>45</sup>
- Existing analogue devices require physical visits and hardware updates whereas new digital devices can be monitored and updated remotely.
- Following the PSTN switch off in Sweden and the subsequent switch to digital alarms, local authorities were able to redirect out of hour calls to a central system, freeing up staff to be deployed as mobile response.<sup>46</sup>

While some of these options are currently possible using existing broadband networks, customer inertia is a barrier to adoption. Encouraging these changes to digital systems through the switch off of the PSTN could revolutionise the sector.

### 4.2.3 Supporting digital inclusion

The move to All-IP will support digital inclusion. There is still a significant minority (6%) of UK adults who do not have access to the Internet. This is concentrated in older age groups where 20% of 65+

---

<sup>43</sup> Now Healthcare Group, 2019, The impact of telehealth and telepharmacy technology on public health service pressure and patient outcomes.

<sup>44</sup> TSA, 2017, [A digital future for technology enabled care?](#)

<sup>45</sup> Careium, 2018, [Digital telecare: The need for a transition to digital systems and the associated opportunities and benefits.](#)

<sup>46</sup> Careium, 2018, [Digital telecare: The need for a transition to digital systems and the associated opportunities and benefits.](#)

do not have access to the internet compared with just 1% of the 18-34 age group.<sup>47</sup> Vulnerable groups are also more likely to lack access to the internet.<sup>48</sup> This inevitably limits the opportunity for these groups to engage with digital goods and services including digital provision of public services.

All-IP will in effect see everyone provided with a broadband line because All-IP is provided with at least 0.5 Mbps of bandwidth (those homes that do not currently have broadband will receive a router for their voice service). This will at least provide access to email and basic browser functionality, and could be the stepping stone to encourage these late adopters to, over time, move to faster broadband services.

Hence the migration, in combination with CPs' activities to promote digital inclusion,<sup>49</sup> presents an opportunity to improve life outcomes for these groups.

### 4.3 The environmental benefits of switching off the PSTN

#### 4.3.1 Energy savings from decommissioned PSTN equipment

As noted, the PSTN technology is power hungry as it uses dated electronic equipment. The electricity used to maintain the UK's PSTN is estimated to be 313 GWh per year<sup>50</sup> across the UK's PSTN providers (KCom, Virgin Media O2 and BT Group).<sup>51</sup> This accounts for over 0.1%<sup>52</sup> of the entire UK electricity consumption each year.

The All-IP networks that will replace PSTN are already in existence since they are the same networks that provide broadband services. Therefore, migration to All-IP will not cause a measurable offsetting increase in power costs since it already exists to provide broadband services.

BT Group already uses 100% renewable energy to power its networks, however, the retirement of the PSTN equipment will lead to a non-trivial reduction on the demand placed on the UK's energy grid. It will therefore support the UK's transition to renewable energy sources.

In addition, there are other environmental benefits to retiring PSTN equipment. There is a vast scale of electronic equipment used in the PSTN that contains many tons of material including precious metals that can be recycled.

---

<sup>47</sup> [https://www.ofcom.org.uk/data/assets/pdf\\_file/0023/238361/online-nation-2022-report.pdf](https://www.ofcom.org.uk/data/assets/pdf_file/0023/238361/online-nation-2022-report.pdf).

<sup>48</sup> "In 2017, 56% of adult internet non-users were disabled, much higher than the proportion of disabled adults in the UK population as a whole, which in 2016 to 2017 was estimated to be 22%." ONS, 2019, [Exploring the UK's digital divide](#).

<sup>49</sup> For example, BT Group have a programme to help build digital skills particularly among older vulnerable or job seekers. See: <https://www.bt.com/about/digital-impact-and-sustainability/building-better-digital-lives>.

<sup>50</sup> BT Group in discussion with Frontier Economics.

<sup>51</sup> Assuming power consumption per line for BT Group reflects power consumption per line for Virgin Media and KCom.

<sup>52</sup> Total UK electricity consumption by final users in 2022 was 286,052 Gwh in 2021. ("electricity consumption by final users", Source: <https://www.gov.uk/government/statistics/electricity-chapter-5-digest-of-united-kingdom-energy-statistics-dukes>

### 4.3.2 Power savings from decommissioned copper network infrastructure

The migration to All-IP technology will enable BT Group to retire its copper network infrastructure once all users have migrated to full fibre. This network consumes significant amounts of power (partly to provide the electrical signal to support analogue phone lines). Full fibre is much more efficient than alternative technologies such as Fibre to the Cabinet (FTTC).<sup>53</sup> According to BT Group, FTTC broadband consumes 2.4 watts per customer, whereas full fibre consumes just 0.3 watts per customer to provide a much higher capacity service.<sup>54</sup>

BT Group claim that retiring *all* its legacy networks (including copper infrastructure and PSTN equipment) will enable power savings of 550 GWh per year,<sup>55</sup> and thereby reduce demand on the energy grid.

## 4.4 All IP will support the take up of full fibre broadband

Migration to All-IP will play an important role in meeting government targets to roll out Gigabit capable networks.<sup>56</sup> As noted above, while migration to All-IP is not directly linked with full fibre roll out, it is a prerequisite for take up of full fibre.

The ability to migrate customers to full fibre is clearly an important aspect of the business case to invest in full fibre. Rolling out full fibre incurs significant costs. Many network operators including Virgin Media O2,<sup>57</sup> Cityfibre, Hyperoptic, Community Fibre, Gigaclear have all announced significant investments to support the roll out of full fibre networks. BT Group itself is investing £15bn to build fibre to 25m premises.<sup>58</sup> The successful migration to All-IP can support full fibre take up as migration to All-IP can provide a “trigger” point for CPs to prompt end users to switch from their FTTC broadband service to a full fibre service when it becomes available.<sup>59</sup>

Full fibre services will support faster broadband than is available using FTTC technologies. This in turn will realise benefits for the UK economy and society. These benefits will include:

<sup>53</sup> FTTC is used to deliver broadband the majority of residential customers in the UK but has limitations on the maximum download speed of around 70 Mbps.

<sup>54</sup> <https://thestack.technology/bt-energy-efficiency-obsession/>.

<sup>55</sup> <https://www.bt.com/bt-plc/assets/documents/investors/financial-reporting-and-news/quarterly-results/fy23/network-investor-day-june22.pdf>.

<sup>56</sup> The government has stated that “By 2030, the UK will have nationwide gigabit-capable broadband and 4G coverage, with 5G coverage for the majority of the population.” <https://www.gov.uk/government/news/government-unveils-levelling-up-plan-that-will-transform-uk>.

<sup>57</sup> <https://news.virginmediao2.co.uk/new-4-5bn-investment-to-extend-virgin-media-o2s-fibre-footprint-to-80-of-the-uk/>

<sup>58</sup> <https://www.openreach.com/fibre-broadband/where-when-building-ultrafast-full-fibre-broadband#:~:text=We're%20committed%20to%20building,investment%20conditions%20are%20in%20place.>

<sup>59</sup> Demand from some consumers for ultrafast broadband enabled by full fibre might be uncertain simply because they have not had the opportunity to experience the benefits that it can offer (it may be an “experience good” where demand increases only *after* consumers use the good).

- **Higher economic growth.** There is an abundance of research which shows that faster, higher quality connectivity leads to higher economic output and economic growth.<sup>60</sup> Research for Openreach estimated that take up of full fibre by 2026 will lead to productivity gains to the UK's economic output, (compared to a case where full fibre is not rolled out) of £54bn<sup>61</sup> by 2030 as firms are more productive. In addition, it found that full fibre roll out will enable a boost to labour participation which will add £18bn to the UK's economic output by 2030. Openreach's research implies that UK economic output will be £72bn a year larger as a result of growth in full fibre.<sup>62</sup>
- **Environment benefits of full fibre networks.** The environmental benefits of full fibre networks are threefold. First, as explained further in section 4.3, full fibre networks are significantly more energy efficient than copper or cable networks. Second, a faster and more resilient network encourages the use of teleworking which enables reduced CO2 emissions. Third, take up of full fibre means that the vast amounts of metal in the copper network can be recycled.

This means that if full fibre roll out is delayed as a result of a delay in migration from PSTN, the UK economy will forgo some of the benefits. Based on analysis conducted for Openreach,<sup>63</sup> Frontier estimate that a two year delay in full fibre roll out (delaying rollout from 2028 to 2030) could lead to lower economic output as a result of lost productivity and workforce participation totalling to £2bn, cumulatively up to 2038 (depending on the proportion of households that do not take full fibre as a result of delay to All-IP).<sup>64</sup>

---

<sup>60</sup> One study shows that broadband adoption increased UK GDP by 5.28% between 2002 and 2016, by facilitating information exchange, teleworking and new services. Moreover, faster broadband speeds enabled by full fibre would increase GDP by 1.38%. This is because it can contribute to increased economy wide productivity, reduced barriers to employment, and supporting innovation and update in new technologies. Koutroumpis, 2018, [The economic impact of broadband: evidence from OECD countries](#).

<sup>61</sup> Meaning the economic output of the UK economy each year will be £72bn higher than in the case where full fibre was not rolled out.

<sup>62</sup> See <https://www.openreach.com/news/openreach-hits-10-million-full-fibre-milestone>. BT will publish a report by CEBR in H1 2023.

<sup>63</sup> CEBR, 2019, Full fibre broadband: A platform for growth. Workforce participation figures updated following changes in CEBR, 2021, Full fibre broadband: A platform for growth. There is an updated report due to be published in H1 2023. See <https://www.openreach.com/news/openreach-hits-10-million-full-fibre-milestone>

<sup>64</sup> The impact of a two year delay in take up of full fibre is based on CEBR estimates of incremental economic output (GVA) enabled by full fibre assuming roll out in 2028 and 2030 (with the difference between the two illustrating the impact of a two year delay in full fibre take up). The delay does not permanently affect the economic potential of the UK, so by 2038 economic output under the 2030 roll out scenario would be the same as output in the 2028 scenario. The estimate of the impact of a delay to All-IP migration assumes that a proportion of the full fibre benefits would be forgone if All-IP were delayed as users, particularly those that do currently take broadband would miss the opportunity to upgrade on All-IP migration.



## 5 BT Group has supported actions to mitigate the migration challenges

While the migration to All-IP will bring benefits and will future proof BT Group's universal service obligation<sup>65</sup> with respect to voice, and more generally the UK's voice service, it is undoubtedly a large-scale operation, with over 19.5 million lines connected to UK PSTN technologies from BT Group, Virgin Media O2 and KCom.

Therefore, it is incumbent on all involved stakeholders to coordinate to ensure that the migration is smooth and orderly so that end users continue to receive their services with limited disruption (as noted, for most users the migration will be a simple case of plugging their phone into their router rather than a wall socket). The managed wholesale migration should also ensure that the business interests of all providers are protected by enabling them to offer services, while transitioning to digital equipment. Since announcing the closure of the PSTN in 2017, more than six million customers have migrated from PSTN to new All-IP services with around two million consumer customers moving to BT's Digital Voice service. BT Group has been involved in a number of activities to support a smooth migration. The purpose is to prepare suppliers, CPs and end users for the change.

In undertaking these actions, which are described in more detail below, BT Group's retail units (BT Consumer and BT Business) intend to make significant exceptional investments (estimated to be £416m) to support the migration. This investment provides residential users with new customer equipment, handsets, battery backup units; it funds staff to support more complex migrations; it will cover costs for communications and marketing.

BT Group's actions to support the migration are summarised below, considering in turn:

- communications and outreach;
- technical preparation for BT Group, other CPs and service providers;
- industry cooperation and coordination; and,
- mitigations for customers with specific needs.

### 5.1 Communications and outreach

BT Consumer has been engaging with consumers, businesses and service providers to prepare them for the switch off in 2025. This has included: consulting with a stakeholder group representing vulnerable customers; marketing campaigns; working with service providers to identify households to be classed as vulnerable; and training specialist sales teams to assist commercial customers with the switchover.

---

<sup>65</sup> The universal service obligation is also applicable to KCOM in the Hull area. See <https://www.kcom.com/universal-service-obligation/>.

For BT Business' 1.2m commercial customers with more complex needs, and a very diverse set of devices that are connected to the network, a specific customer outreach and communication programme has been developed. BT Business has categorised its customers depending on the complexity of their needs with dedicated programmes for each of CNI providers, larger corporate customers, small and medium enterprises, and Small Office and Home Office (SOHO). BT Business has specifically trained employees who handle their migration to ensure it is as smooth as possible.

CNI customers have specific needs given that their services are, by definition, critical for the UK's security. Given the sensitive nature of migrating these customers, this can involve discussing the migration with them over a period of months to years. For more complex cases BT Business provides a free of charge survey and review of their services to support their migration to the new technology.

Openreach has conducted a programme of industry outreach and engagement. The purpose is to support communications providers and service providers that use PSTN communications (whether telecare, alarm providers, lift providers, or utility suppliers) to prepare for migration.

### 5.2 Technical preparation for BT Group, other CPs and service providers

In anticipation of this migration, Openreach, BT Consumer and BT Business has been progressively upgrading its network and implementing substitute services at both a retail and wholesale level.

Openreach has undertaken trials in Salisbury and Mildenhall to identify issues and potential solutions associated with the migration. In these areas the closure of PSTN services is earlier (April 2023) than the rest of the country (December 2025) and both trial areas have already stopped selling new products which are reliant on the PSTN such as Wholesale Line Rental (WLR) services.

BT Group, Openreach and other CPs<sup>66</sup> have opened labs for device manufacturers and suppliers to test their equipment. The labs have already detected issues with the configuration of some devices and CPs are providing support to address the issues.

Anyone who manufactures or distributes devices and equipment can use BT Group's test facilities.<sup>67</sup>

### 5.3 Industry cooperation and coordination

Network providers understand the concerns of customers and together with impacted industries, are working to address all concerns.

---

<sup>66</sup> Both BT Group and Virgin Media have opened testing labs, see <https://www.openreach.co.uk/cpportal/products/the-all-ip-programme/digital-services-test-lab> <https://www.virginmedia.com/corporate/blogs/ip-voice-lab>.

<sup>67</sup> Some service providers have reported that they cannot directly test devices, since they claim only device manufactures can use these test labs. However, BT Group notes that this is not the case. BT has a dedicated special service page where they give an overview of the testing facilities (see: <https://www.bt.com/about/special-services>). It also has a page to show who has tested (see: <https://www.bt.com/about/special-services/whos-tested>). Openreach also have a dedicated page where they publish the names of organisations, councils and housing associations who've attended and tested their kit (see: <https://www.openreach.co.uk/cpportal/products/the-all-ip-programme/digital-services-test-lab>).



The Department for Science, Innovation and Technology (DSIT), supported by Ofcom, is undertaking coordinating actions within government to ensure government departments with responsibility for sectors affected by the migration are aware and engaged.<sup>68</sup> Ofcom has provided guidance to CPs on its expectations with regard to the migration in relation to service provision and access to emergency services.

Since 2017 Ofcom has created two All-IP working groups.

- The Technical All-IP Working Group facilitates collaboration between CPs, providers of downstream services and other key stakeholders. This is with the aim to further smooth the process of sharing information on timetables, difficulties of migration and implications for downstream services.<sup>69</sup>
- The Communications Working Group was created to enable CPs to share information on best practice around consumer communication in relation to the migration to All-IP. This has been done through developing common terminology and discussing challenges faced by providers migrating consumers.<sup>70</sup>

In addition, the Office of the Telecommunications Adjudicator<sup>71</sup> (OTA2) has a role to implement processes that enable non-BT CPs to access Openreach services. It has set up a variety of working groups which BT Group and other CPs take part in including on migration to All-IP and has produced best practice guidance on the migration processes.<sup>72</sup>

The NICC (Network Interconnect Consultative Committee) is an industry body which designs and implements technical standards for telecommunications services. Its members are telecommunications providers and equipment suppliers.<sup>73</sup> It has an All-IP Task Group which is developing new standards and reviewing existing standards in relation to the migration.<sup>74</sup>

### 5.4 Mitigations for customers with specific demands for their PSTN service

BT Consumer has been working with users and device manufactures to overcome concerns related to users with specific demand for their PSTN service.

#### Devices that operate during power outages

---

<sup>68</sup> Such as government departments with responsibility for health, energy, transport and business.

<sup>69</sup> Ofcom, 2019, [The future of fixed telephone services](#).

<sup>70</sup> Ibid.

<sup>71</sup> <http://www.offta.org.uk/latest-news>.

<sup>72</sup> <http://www.offta.org.uk/best-practice-guide>.

<sup>73</sup> NICC is an independent organisation owned and run by its members, of which there are three membership classes – Full (open to all telecommunications providers and organisations with an operating presence or other interest in the UK and the equipment supplier community), Associate (similar to Full membership but unable to attend board meetings and do not have voting rights on NICC standards) and Observer (currently Ofcom and DSIT – can attend board meetings in a non-voting capacity).

<sup>74</sup> <https://niccstandards.org.uk/current-work/#bookmark1>.

To address concerns that power outages at customers' premises might interrupt digital communications services (since All-IP is not powered from the exchange with backup power unlike PSTN) a wide range of products have been developed.

These devices include battery back-ups and "hybrid" phones with 4G connectivity to enable connectivity on 4G networks where the fixed voice service is interrupted. A battery back-up (BBU) can be connected to the BT Smart Hub, and in the event of a power outage will power the Hub to enable voice calls to be made for a period of time. The coverage and reliability of 4G networks in rural areas has significantly improved, partly as a result of initiatives such as Emergency Services Network (ESN) and Shared Rural Network (SRN). This makes hybrid phones a viable option in rural areas to provide guaranteed connectivity even during power outages.

All products are provided free of charge to vulnerable users who are the focus of concerns. BT Consumer has expanded its definition of vulnerability to ensure that access to mitigation solutions is as wide as possibly necessary.

### **Supporting device manufacturers to upgrade and adapt PSTN devices**

All CPs want to ensure vulnerable customers have functioning devices following the All-IP migration. Of most concern are users of telecare devices who rely on the service for their health and wellbeing. These customers are actively identified, so that their devices can be checked for compatibility with digital lines, and if so replaced.

CPs have been working with alarm receiving centres (ARCs) to identify potential users of telecare devices.<sup>75</sup> Moreover, CPs have engaged PSTN service providers to ensure they are aware of the migration and to inform them of the steps that they need to take. All service providers are aware that they need to test their old equipment's compatibility with All-IP and potentially purchase replacement equipment.<sup>76</sup>

### **Responsibility for electricity provision is beyond the scope of telecommunication providers**

The PSTN has been able to provide a powered communications network over copper wires, since this was how the communication technology was configured to deliver BT Group's Universal Service Obligation. However, this does not mean that BT Group and other CPs have an obligation to supply electricity to its customers as the network technology is upgraded.

Businesses that have to date relied on the PSTN to supply electricity to their devices, or require a very resilient power supply, may have to look to other solutions, and to their power network and infrastructure providers, if BT Group's All-IP services do not offer the equivalent power related

---

<sup>75</sup> It is possible to identify a PSTN user as a telecare user where the device has called an ARC.

<sup>76</sup> BT Group, Openreach and Virgin Media all have digital service testing labs for service providers to test old and new equipment to ensure functionality.

functionality that they require.<sup>77</sup> For those businesses with edge use cases (such as water telemetry lines) network operators must explore technical solutions for these customers.

For example, businesses that require a powered communication service could look to install a battery backup or generators. Businesses that require a backup communication service to provide resilient emergency communication could use 4G communications. These can be enabled even where the user is in a basement of a building by powered (with backup) internal wiring to an external 4G antenna.

---

<sup>77</sup> Ofgem recently published a report with clear actions for electricity distribution network operators to help them increase the resilience of the networks, particularly in response to extreme weather. See: <https://www.ofgem.gov.uk/publications/storm-arwen-report>.

## 6 Conclusions and recommendations

The migration to All-IP in 2025 is needed to ensure that the UK has a resilient and reliable voice communications network. Embracing the transition, the UK is proactively addressing the challenges posed by the outdated PSTN technology, which has become increasingly unreliable and costly to maintain. This will reduce the risks of large-scale outages, ensuring uninterrupted communication for all users, including vulnerable individuals and businesses who heavily rely on the network. Additionally it enhances the ability of CPs to support a range of services and helps BT Group to continue to fulfil its USO by providing a universal voice service.

Migrating to All-IP would lead to cost savings to the UK.<sup>78</sup> These include reducing the costs associated with increased faults (£22m); the benefit to users who are able to enjoy All-IP, such as its ability to reduce fraud equating to savings of £1.7bn assuming a two year delay (up to £165m p/a in financial losses and £685m p/a in welfare cost of emotional distress). In addition, ensuring a timely delivery of the PSTN migration would ensure that the UK's productivity and economic output could be maximised as the roll out and take up of full fibre will not be delayed, potentially cumulatively amounting to £2bn by 2030<sup>79</sup>.

Since announcing its intention to migrate customers in 2017, giving all stakeholders eight years to prepare, significant progress has been made to be ready for the change. All CPs are actively preparing for the migration and have undertaken programmes to reach out to their users. BT Group, Openreach and Virgin Media have opened labs which enable CPs and PSTN device manufacturers to test their new devices. Several industry level working groups exist to support and manage technical and communications aspects of the change. In order to support the migration BT Group has made a commercial decision to work with industry to provide backwards compatibility with analogue devices as far as practical (for example using Analogue Telephone Adapters). Notwithstanding the work of BT Group and other CPs, there are limits to what can be provided. For example, it is not the responsibility CPs to provide power for their customers.<sup>80</sup>

Nonetheless challenges remain. Migrating 19.5 million UK lines to a new network is a big challenge, made more difficult by the wide range of stakeholders involved including other PSTN CPs, CPs that own the retail customer relationships, service providers that use PSTN to deliver their services, businesses users, local and national government, and consumers. A significant proportion of business users are not aware of the need to migrate or are not actively considering their migration options. Vulnerable users will need support to migrate their devices. Anecdotally some PSTN service providers have said that the process for testing new devices is cumbersome.

<sup>78</sup> This does not include the costs to BT Group of a delay which would amount to £372m.

<sup>79</sup> As noted in section 4.4 there is a degree of uncertainty over the extent to which All-IP migration will lead to increased take up of full fibre.

<sup>80</sup> For example in relation to support for analogue devices BT Group has made a commercial decision to work with industry to provide backwards compatibility with devices as far as practical (for example using Analogue Telephone Adapters). But in a fully liberalised market BT Group is not under a regulatory obligation to provide solutions for all customers, such as to provide power to its customers.

This suggests that there are a number of actions that could be undertaken to support a successful migration.

### Government support for the migration

The government has a clear interest in supporting the migration.

- The migration relates to a critically important part of the UK's national digital infrastructure, on which business and society depends.
- Government has a direct responsibility for many of the 2m vulnerable customers who use PSTN for their telecare services.
- The migration will support a wide range of "externality" benefits (i.e. benefits to the UK as a whole, not just to the CPs such as BT Group, Virgin Media O2 and KCom with responsibility for the migration).

While industry has put in place a wide range of initiatives to ensure the migration is a success for each and every customer, there is a role for government to address potential communication and coordination failures as the deadline approaches.

- **The migration should be supported by a simple, clear and consistent communication message which is endorsed by all stakeholders.** The migration will be a success where there is a clear and consistent communication message, which is supported by government, and takes place at different levels, from national down to community level. While individual CPs will of course need to reach out to their customers, there is a risk that a piecemeal approach to communication could lead to confusion and low engagement from users. Therefore, all stakeholders should coordinate and align around a common and consistent communication message to engage the public in the transition.
- **The Government and Ofcom can play a strong supporting role in the communication strategy.** Despite many years of preparation, and public information campaigns, awareness of the change is worryingly low for some groups. Communication from government and Ofcom can provide trust and credibility; increase the number of channels through which consumers learn about the migration; highlight the importance of the migration programme for wider UK objectives around digital connectivity and accessibility; and provide reassurance to end users that the migration process is not a sales exercise by their provider. For a large-scale technology shift, which has importance to the whole UK, it is essential that the government and Ofcom use its influence to play a strong supporting role in the communication strategy.
- **The Government should support coordination among affected stakeholders such as DHSC, local government, and service providers.** The PSTN migration process is complex, requiring coordination of many different bodies including the three CPs with PSTNs, CPs that own the retail customer relationships, service providers and government agencies.
- **Ofcom can play a positive role in ensuring that all CPs (including CPs that have the retail customer relationships, but do not have PSTN equipment) contribute to the effort in actively preparing and migrating their customers.** Ofcom can provide reassurance to the

public that CPs do not sell equipment which will be obsolete and incompatible with All-IP or could otherwise mislead customers.

### Coordinating the migration programmes of the CPs

- **A staged regional switch off could help the migration.** This would enable resources to be targeted in each area and learnings to be undertaken from each stage. Whilst some UK business customers may wish to engage and migrate nationally, this regional approach has been successfully followed in many countries such as New Zealand, Germany, Switzerland and France.<sup>81</sup>

### Testing of telecare devices that use phone lines should not be a bottleneck to migration

There are many millions of devices that currently use PSTN lines to provide basic data communication, whether telecare devices, alarms, or monitoring devices. Service suppliers who use these devices and supply them to end users will have to ensure they are compatible with All-IP services, and if not compatible, the devices will need to be swapped out. In order to ensure that the devices are compatible they can be tested at dedicated labs that have been set up by CPs.

- **CPs should ensure that there are no barriers to using the testing facilities.** As the 2025 PSTN switch off approaches it will become ever more important that device manufacturers are able to use and access the testing labs.
- **All service providers should be strongly encouraged to source and test new devices well in advance of the 2025 deadline.** Devices need to be checked for compatibility with the All-IP network and if not compatible, they need to be replaced. However, many service providers are only just starting the procurement process for replacement devices and some stakeholders have anecdotally expressed concerns that there may not be enough digital products to replace all the analogue ones within the time.

### Migrating customers with more complex needs

- To ensure that their migration is smooth and without interruption a number of actions could be taken. **The protocol and standards for facilitating the migration in individual's homes should include specific plans for vulnerable users to ensure that migration does not occur where a vulnerable user's device is not compatible with All-IP.** For business customers with edge use cases, telecoms network operators should ensure that technical solutions are available to provide connectivity to those customers ahead of the 2025 deadline.

---

<sup>81</sup> Plum, 2018, Preparing the UK for an All-IP future: experiences from other countries, page 7.

## Annex A - Modelling assumptions

### A.1 Welfare costs of outages

#### A1. Project number of outages.

There are 19.5m PSTN lines in the UK,<sup>82</sup> with an average availability of 99.9936%<sup>83</sup> between September 2021 and September 2022. There was therefore 650 million lost minutes (457,000 lost days) in a year.

#### A2. Apply this to numbers of lines and future availability

An assumption is made that the number of PSTN lines has a linear drop off ending in 2025, against a counterfactual of a two year delay before a linear drop to switch off in 2027. A further assumption of a midpoint in PSTN availability of 99.845%, this accounts for a pessimistic scenario of 2 more years of similar decline before an acceleration in faults, and an optimistic scenario of some stabilisation in faults with a reduction of 50% of annual variance. This is compared to the target availability of 99.9969% to achieve a below target figure.

#### A3. Estimate numbers of residential voice, telecare (2m) and business users.

Approximately 89% of PSTN lines are consumer with the remaining 11% assigned to business lines.<sup>84</sup> An assumption is made that this proportional split holds with the continued PSTN migration into the future and across other NPs.

#### A4. Estimate welfare impact of an outage.

Valuing the utility / welfare loss resulting from a fault is difficult. It relates not just to the value of being unable to make outgoing calls but also to the inability to receive incoming calls for a period. While average fault times are relatively low, these averages are likely to mask a smaller number of longer outages. To proxy the average welfare cost of a fault this analysis uses the compensation payment recommended by Ofcom of £8.40 per calendar day without service. This is also in line with a study in which ComReg estimated the welfare cost of a voice fault to be €10.40 per day in 2008 which equates to £8.67 assuming an exchange rate of €1.2:£1.<sup>85</sup> This is applied to all lost consumer minutes, uplifted into future years with the target rate of inflation (2% CPI).

Valuing the loss to vulnerable users, such as those using telecare devices is difficult. This is due to the need for reliability and the risk to life should this reliability be unavailable. However, whilst unable to capture this effect, there have been studies to suggest the willingness to pay for telecare is between

<sup>82</sup> BT Group, 2022, Q1 FY23 KPI's.

<sup>83</sup> Data provided by BT Group.

<sup>84</sup> BT Group, 2022, Q1 FY23 KPI's.

<sup>85</sup> Appendix C 3.24 ComReg, 2008, [Response to Consultation – Eircom's Universal Service Obligation](#).



£242-310 per person<sup>86</sup> (equivalent to £0.66-£0.85 a day). There is also an effective saving for local councils who can reduce their social care budgets. In Lancashire this figure was £4,500 per person per annum<sup>87</sup> (equivalent to £12.23 a day). This means that the total welfare loss per day is £13.20. In 2022 there were 1,700,000 lines effected by faults,<sup>88</sup> of which the assumption is made that each is only affected once. Of these, the assumption is made that 11% (2 million) are telecare users. As such the additional welfare lost due to outages for a telecare user is £2.5m p/a and £5m as a result of a 2 year delay.

Valuing the impact of faults on businesses is complex as businesses are very heterogeneous in their use of PSTN. This has been done using the BT Business compensation scheme of 1 week's rental credit for each day that a fault has not been repaired.<sup>89</sup> An estimate for rental credit has been achieved by dividing the total revenue of WLR for BT Business £2.3bn by 1.37 million lines it operates.<sup>90</sup> This gives a compensation figure of £32.75 per day.

### A.2 Estimating productivity and labour participation impacts

As set out in the report delaying migration to All-IP could delay take up of full fibre broadband. The successful migration to All-IP can support full fibre take up as migration to All-IP can provide a “trigger” point for CPs to prompt end users to switch from their FTTC broadband service to a full fibre service when it becomes available. This in turn could put at risk some of the productivity benefits associated with full fibre broadband. The assessment of the scale of this impact the analysis uses analysis conducted by CEBR to estimate the productivity benefits associated with full fibre broadband, and in particular the analysis demonstrates the impact of a delay in full fibre roll out and take up. These estimates are then down weighted to reflect the proportion of full fibre users that could be affected by a delayed All-IP migration, and the proportion of productivity benefits that could be ascribed to this group.

#### A delay in full fibre roll out and take up

The 2019 CEBR<sup>91</sup> report the impact of full fibre roll out estimated GVA gained figures as a result of full fibre rollout to 2028 and 2030. Adjusting these for the 2022 monetary values and the 2021 reports updated workforce participation numbers allowed a comparison of the difference to estimate lost GVA. This difference is outlined in Figure 5.

---

<sup>86</sup> Stephen & Sultan, 2014, see <https://journals.sagepub.com/doi/10.1177/1357633X14528445?icid=int.sj-full-text.similar-articles.4>.

<sup>87</sup> Tunstall Healthcare, 2018, Lancashire County Council – Telecare at Scale, see <https://www.homecareinsight.co.uk/study-reveals-how-telecare-is-saving-councils-millions-in-social-care-costs/>.

<sup>88</sup> Data provided by BT Group.

<sup>89</sup> <https://business.bt.com/compensation-scheme/>.

<sup>90</sup> BT Group, 2022, Q1 FY23 KPI's.

<sup>91</sup> This is based on analysis produced by CEBR. See <https://www.openreach.com/fibre-broadband/full-fibre-impact>. There is an updated report due to be published in H1 2023. See <https://www.openreach.com/news/openreach-hits-10-million-full-fibre-milestone>



Figure 5 Difference in GVA following a 2028 and 2030 rollout

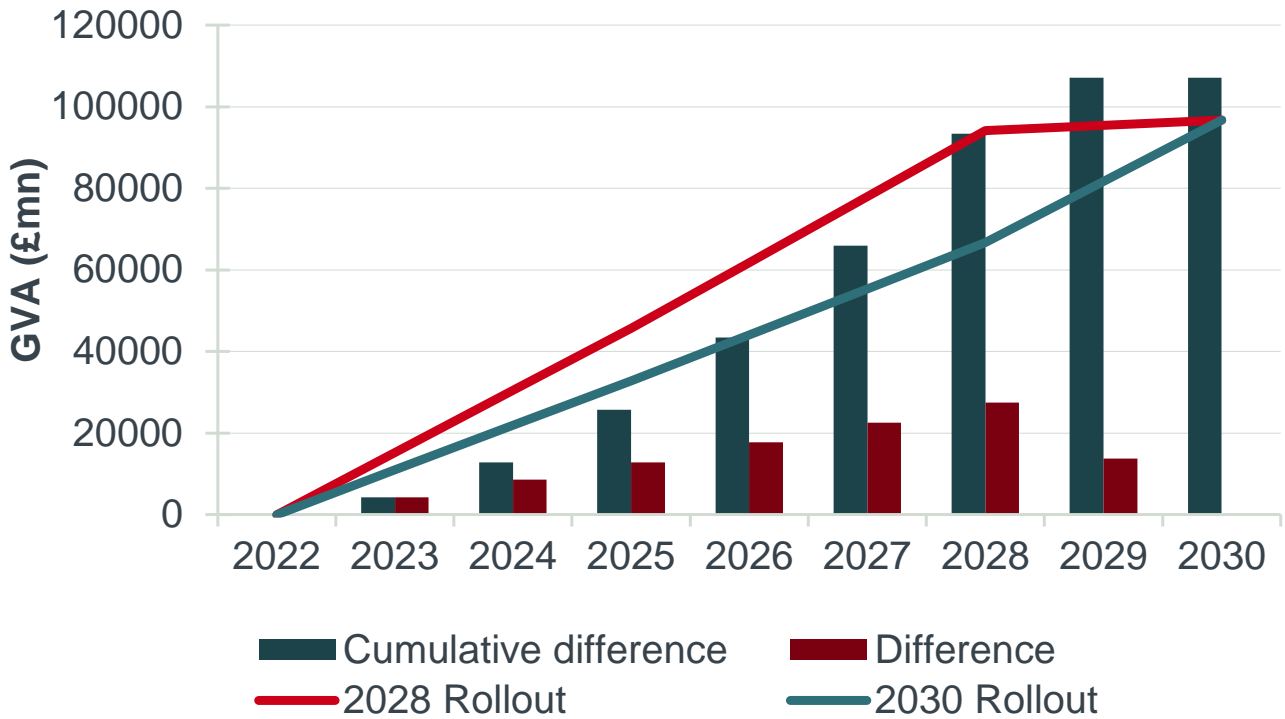

Source: Frontier Economics

**Down-weighting productivity gains to reflect the proportion of full fibre users affected by an All-IP delay and their contribution to productivity gains**

The productivity gains associated with the roll out of full fibre are assumed to scale with take up of ultrafast broadband services. The group of customers most likely to take broadband, as a result of PSTN migration, are those who currently do not have a fixed line broadband service. Therefore the impact of a delay in All-IP migration is restricted to this subset of customers (i.e. the 1,100,000 customers currently on a landline only). A further assumption is made that as the switch off of the PSTN is only a stepping stone to full fibre and hence there is not a direct relationship between delayed All-IP and full fibre hence 25% of the scaled productivity benefits are assumed to accrue to the UK as a result of this group of customers being prompted to take broadband. As such the GVA uplift is estimated to be £2bn.

## A.3 Number of PSTN lines

Table 1 Number of PSTN lines

	BT <sup>92</sup>	VM <sup>93</sup>	Kcom <sup>94</sup>	Total
Lines	15,000,000	4,380,000	165,000	<b>19,545,000</b>
Business	4,000,000	n/a	18,305	
Consumer	11,000,000	n/a	146,695	

<sup>92</sup> Total BT lines. [https://www.openreach.com/content/dam/openreach/openreach-dam-files/images/upgrading-the-UK-to-digital-phone-lines/industry/openreach\\_ALL\\_IP%20and%20WLR%20Withdrawal%20Industry%20Update%20Jan%202021.pdf](https://www.openreach.com/content/dam/openreach/openreach-dam-files/images/upgrading-the-UK-to-digital-phone-lines/industry/openreach_ALL_IP%20and%20WLR%20Withdrawal%20Industry%20Update%20Jan%202021.pdf). Total consumer lines reflect BT WLR consumer lines as reported in BT Regulatory Financial Statements 20/21. <https://www.bt.com/bt-plc/assets/documents/about-bt/policy-and-regulation/our-governance-and-strategy/regulatory-financial-statements/2021/regulatory-financial-statements-2020-21.pdf>

<sup>93</sup> Virgin Media relates also includes managed VoIP and may overestimate its PSTN lines. [https://www.ofcom.org.uk/\\_data/assets/pdf\\_file/0022/246208/Q2-2022-Telecoms-Data-Update.pdf](https://www.ofcom.org.uk/_data/assets/pdf_file/0022/246208/Q2-2022-Telecoms-Data-Update.pdf).

<sup>94</sup> <https://www.kcom.com/media/topa4ew3/kcom-ofcom-statements-2020-21.pdf>.

## Annex B - Glossary

<b>IP</b>	Internet protocol – the technology standard used to convey digital information
<b>PSTN</b>	Public Switched Telephone Network - the term for the legacy analogue network that is used to route voice calls.
<b>USO</b>	Universal Service Obligation - government legislation that gives eligible UK addresses the right to request a voice service and 'decent' broadband connection
<b>CP</b>	Communication Provider – a provider of telecommunications services
<b>NP</b>	Network Provider – These are a subset of the communication providers which build and operate their own network infrastructure
<b>FTTC</b>	Fibre to the Cabinet – a broadband service to connect to the internet using fibre optic cables from a local exchange to fibre cabinets and copper wires from the cabinet to the premises
<b>Line cards</b>	The circuit board that interfaces subscribers' premises equipment connection to the telecom network.
<b>WLR</b>	Wholesale Line Rental – a wholesale service provided to CPs that provides voice and basic data to end users over the PSTN.
<b>Critical National Infrastructure</b>	A customer is considered Critical National Infrastructure if disruption is life or death preventing or related to defence of the realm

Frontier Economics Ltd is a member of the Frontier Economics network, which consists of two separate companies based in Europe (Frontier Economics Ltd) and Australia (Frontier Economics Pty Ltd). Both companies are independently owned, and legal commitments entered into by one company do not impose any obligations on the other company in the network. All views expressed in this document are the views of Frontier Economics Ltd.